

NIT NO	RBO-IV,PATIALA/10
DATE	06/04/2026



STATE BANK OF INDIA

E-TENDER DOCUMENT FOR

PROPOSED ELECTRICAL WORKS OF BRANCH & E-LOBBY AT SBI,

KHANAURI- 50188 BRANCH

IN PUNJAB

(TIME BOUND WORK)

TENDER NOTICE

THROUGH E-TENDERING PROCESS

Interior Contractors who are on the panel of

SBI, Chandigarh Circle,(LHO)

in the Appropriate category are only eligible

TECHNICAL BID

Last date for submission of e-tender:- 20/04/2026 by 3.30PM

State Bank of India (SBI) Invites Online Tenders from the Empaneled ELECTRICAL WORKS Contractors of SBI at Chandigarh for the E-TENDER FOR THE PROPOSED ELECTRICAL WORKS OF BRANCH & E-LOBBY AT STATE BANK OF INDIA, KHANAURI-50188 BRANCH IN PUNJAB.

1	Name of the work	<u>E-TENDER FOR ELECTRICAL WORKS OF BRANCH &amp; E-LOBBY AT STATE BANK OF INDIA, KHANAURI- 50188 BRANCH IN PUNJAB.</u>
2	Estimated cost	Rs.11,62,216 .00 /-+ plus GST
3	Cost of Tender Documents	NIL
4	Quantum of Earnest Money Deposit(EMD)	Rs.11,650/-Drafts/BCs shall be in favor of "State Bank of India," Payable at PATIALA. " MSME/NSIC Certificates will not be accepted for exemption of EMD"
5	Date and Time where tender forms are available	From 07/04/2026 till 20/04/2026 upto 3:30 pm at <a href="http://www.sbi.co.in">www.sbi.co.in</a> /SBI in the News procurement-news and <a href="https://www.tenderwizard.com/SBIETENDER">https://www.tenderwizard.com/SBIETENDER</a>
6	Last date and time of submission of online Tender	20/04/2026 upto 3:30 pm
7	Place, date & time for submission of e-tender Contact person /telephone no/ email address.	a) On line submission of e-Tender (Including Technical Bid and Price Bid) up to 20/04/2026 upto 3:30 pm at <a href="https://www.tenderwizard.com/SBIETENDER">https://www.tenderwizard.com/SBIETENDER</a> b) EMD submission Address: The Chief Manager( Operations) State Bank of India, Regional Business Office.-IV, SBI BUILDING,Sharan wala Gate, The Mall,Patiala.-147001 20/04/2026 upto 3:30 pm Contact Desk Officer: Mr. Sham Lal-9779585624. Mail: cmcs4.zomohali@sbi.co.in.
8	Date, Time and Place of opening of e-Tender	Online on 20/04/2026 upto 05 : 00 pm . The Chief Manager( Operations) State Bank of India, Regional Business Office.-IV, SBI BUILDING,Sharan wala Gate, The Mall,Patiala.
9	Quantum of Security Deposit(percentage)	1. Initial Security Deposit (ISD) -2% of the Tender value including EMD 2. Retention Money-5%of the running bills and Total deduction of 5% of value of work including EMD, ISD.
10	Terms of payment of Bills, if any (specify the mini-mum value of work for payment of running account bills)	Minimum value of Running bill value-6 Lakhs and above

11	Stipulated time for completion of the Work/supply.	60 Days from the date of the work order issued to the contractor
12	(Penalty clause)Liquidated Damages	@0.5% of the value of work per week of delay subject to a maximum penalty of 5%of the value of work would be strictly imposed.
13	Validity period of the tender.	Three(3)Months
14	Defect Liability Period	Twelve(12)Months
15	Eligible Taxes	<p>A) Income Tax &amp; GST IT will be deducted at source as per Govt. Guidelines.</p> <p>B) Reimbursement of GST will be made only on submission of proper GST invoice as per applicable GST provision. The con-tractor should comply with the following;</p> <ol style="list-style-type: none"> <li>1. Contractor should have GST Registration Number</li> <li>2. Invoice should specifically/separately disclose the amount of GST levied at applicable rate as per GST provision</li> <li>3. In case of Correction in the bills after scrutiny, contractor should submit fresh bills for payment</li> <li>4. Contractor should timely file his GST return in accordance with GST provisions to enable the bank to claim the credit of GST paid to the contractor</li> <li>5. The GST Number of State Bank of India, PUNJAB State -03AAACS8577K1ZZ</li> </ol>
16	Electronic Payment	Payment shall be made by way of Electronic fund transfer and the bill will be paid by the Branch. Firm should furnish details of the bank, a/c no, IFSC code
17	Agency for arranging on-line bidding	<p>M/s. Antares Systems Limited, Registered Office: #24, Sudha Complex, 3rd Stage, 4th Block, Bangalore-560079,Karnataka. Help Desk: 7503347659 / 9044314492/ 9073677150/ 151 / 152 /9674758506/9674758723/26 Contact Persons:(On working days 9AM to 6PM) 1.Mr.Pravesh Mani No.:+919044314492 e-Mail: <a href="mailto:praveshmani.t@antaressystems.com">praveshmani.t@antaressystems.com</a> 2.Mr.Abhay kr singh Mobile No.:+919708966660 e-Mail:<a href="mailto:abhaykumar@antaressystems.com">abhaykumar@antaressystems.com</a></p>
18	Any additional information	The quoted rate should be inclusive of materials, labour, wages, fixtures, transportation, installation, all taxes (excluding GST),wastages, Octroi, machinery ,temporary works such as scaffolding, cleaning ,overheads, profit, statutory expenses, incidental charges and all related expenses to complete the work

19	EVALUATION OF PRICE BIDS AND FINALIZATION	<ol style="list-style-type: none"> <li>1. Only those Bidders who qualify in Technical evaluation would be shortlisted and the online price bids submitted by the bidders will be opened. However these Indicative Price Bids would remain undisclosed to the Bidders.</li> <li>2. The E-Tender will be either of the Estimated Amount or the Lowest Online Price Bid submitted by the Bidder.</li> <li>3. The L1 Bidder will be selected on the basis of net total of the price evaluation as quoted in the Online.  If the final L1 bid is unreasonably low i.e.L1 bid is less by 10% or more of the Estimated Cost, the contractor shall submit additional Security Deposit in the form of PBG/DD for an amount equal to difference in the 92.5% of the estimated cost vis-à-vis final tender amount quoted by the L1 contractor. PBG/DD to be submitted within 7 days from issue of letter from Bank.</li> <li>4. If the L1 bidder refuses to give the PBG, then the EMD will be forfeited and the tender will be re-invited. The L1 bidder will not be allowed to participate in the retendering process.</li> </ol>
----	-------------------------------------------	----------------------------------------------------------------------------------------------------------------------------------------------------------------------------------------------------------------------------------------------------------------------------------------------------------------------------------------------------------------------------------------------------------------------------------------------------------------------------------------------------------------------------------------------------------------------------------------------------------------------------------------------------------------------------------------------------------------------------------------------------------------------------------------------------------------------------------------------------------------------------------------------------------------------------------------------------------------------------------------------------------------------------------------------------------------------------------------------------------------------------------

1. Scanned copy of EMD must be uploaded and the same needs to be submitted at given address within due date of tender.
2. Firm can visit the website (<https://www.tenderwizard.com/SBIETENDER>) till last date of submission for changes. Corrigendum if any will be published only in <https://www.tenderwizard.com/SBIETENDER>
3. L-1 Tenderer signed copy of entire tender document should be submitted within 3 days from date of tender opening.

CHIEF MANAGER,  
STATE BANK OF INDIA

## INSTRUCTIONS TO TENDERERS

Online, E-tenders are invited for PROPOSED ELECTRICAL WORKS OF BRANCH & E-LOBBY THE STATE BANK OF INDIA, KHANAURI-50188.(PB).

1. Submission of BIDs/Tender Documents: Tenders should be submitted online in the website <https://www.tenderwizard.com/SBIETENDER>. In addition, scanned copy of the declaration given in the tender to be signed with seal and scanned proof of dealership/empanelment letter certificate should be submitted on-line with our service provider on the website at :<https://www.tenderwizard.com/SBIETENDER>.
2. Contractors should submit/send **EMD physically within due date of the tender** at the office address mentioned the in NIT document. The tender will be rejected if the tenderer fails to submit the EMD.
3. Contract documents consist of detailed plans, technical specification, schedule of quantities of the various classes of work to be done, and the set of' conditions of contract' to be compiled with by the person whose tender may be accepted. The documents are available in the website <https://www.tenderwizard.com/SBIETENDER>
4. Tenders should be submitted online (**As mentioned in NIT**).
5. **EMD amount (As mentioned in NIT)** is to be deposited in the form of Demand Draft/ Banker's Cheque payable at **PATIALA** and drawn in favor of State Bank of India, otherwise the tender is liable for rejection.
6. The successful tenderer will have to pay an amount of Initial Security Deposit, which shall be 2% of the accepted value of the tender, by means of D.D. in favor of **State Bank of India, PATIALA**. The Initial security deposit is to be paid by the Contractor to Bank within 7 days of intimation to him of the acceptance of the tender. No interest is allowed on the above said security deposit(EMD,ISD)
7. Retention Money: From each running bill, an amount at the rate of 5% of the gross value of the running bill shall be recovered as retention money, till the total retention amount including the EMD and ISD amounts already with the Bank become 5% of the value of the contract amount.  
This amount is called as Total Security Deposit, which consists of three components
  - a) EMD-Earnest Money Deposit.
  - b) ISD-Initial Security Deposits.
  - c) RM-Retention Money.

The total security deposit will be kept with the Bank. And total security deposit may be refunded after the end of defects liability period (**one year**), provided he has satisfactorily carried out all the works and attended to rectification of all defects in accordance with the conditions of the contract. In case of failure on the part to do so, the cost of rectifying the defects through any other agency shall be deducted from the amount of security deposit due to the contractor.
8. Completion of work:
  - i) The work shall be considered as complete only when the certificate of virtual completion is issued by the architects/Bank.
  - ii) The defects liability period as prescribed in the contract shall commence only from date of such virtual completion.
  - iii) Any defect that may appear within the defects liability period shall be rectified

by the contractor within reasonable time on receipt of necessary instructions from Bank to that effect.

9. The acceptance of a tender will rest with the Competent Authority, who does not bind himself to accept the lowest tender and reserves to himself the authority to reject any or all the tenders received, without assigning any reasons. All tenders in which any of the prescribed conditions are not fulfilled or are in complete in any respect are liable to be rejected.
10. All compensation or other sums of money payable by the Contractor to Clients under the terms of this contract may be deducted from the security deposit, or from any sum that may be or may be come due to the Contractor on any account whatsoever and in the event of the Security Deposit being reduced by reasons of any such deductions, the Contractor shall within 7 days of being asked to do make good in by DD any sum which have been deducted from his security deposit.
11. Tender containing any condition leading to unknown/indefinite liability ,are liable to be summarily rejected.
12. Canvassing in connection with tenders is strictly prohibited and the tenders submitted by the contractors who resort to canvassing will be liable to rejection.
13. The tenderer should quote their(own) rates for undertaking the work.
14. GST as applicable will be reimbursed by Bank as specified in NIT.
15. All taxes other than GST, other statutory obligation in respect of this contract, as applicable, shall be payable by contractor including transportation and TA/DA of the workers at site and the Bank will not entertain any claim whatsoever in this respect.
16. I.T. will be recovered as per Government Rules
17. Time is the essence of the contract. The work should be completed on time as mentioned in the NIT. The successful Contractor will have to give CPM/PERT chart of various activities of works to be done so that the work gets completed within the stipulated time. The chart shall be submitted within 7 days from the date of acceptance of the tender.
18. Tenders for works shall remain open for acceptance for a period of 90 days from the last date of tenders. If the tenderer withdraws his tender before the expiry of the said period or makes any modifications in terms and condition of the tender which are not acceptable to the Bank, then the bank without prejudice to any other right or remedy is at liberty to forfeit the earnest money.
19. The successful tenderer, after the work is awarded, he will have to enter into an agreement with the competent authority of the bank.
20. The tenderer must co-ordinate with the other agencies such as Interior/Furnishing/ Electrical/IT/Fire/AC etc.
21. The tenderer should visit the site to ascertain the working conditions and local authority regulations / restrictions if any and other information required for the proper execution of the work.
22. The work may be carried out on any floor level as per site condition. Please note that materials and machines are required to be carried on head load and the same must be accounted in the costing. Please note that no separate cost shall be allowed for head load.

23. The quantities of various items given in the schedule of quantities are approximate. The quantities of work may vary at time of allotment / execution of work. Bank reserves the right to omit / delete any item(s) of work from the schedule at the time of allotment / before. Contractor will be paid for the actual work done at the site duly verified by the concerned official of the bank.
24. The unit price shall be deemed to be fixed price. In case of extra items, a record of labour charges paid shall be maintained and shall be presented regularly to the Employer's for checking. The settlement will be made based on figures arrived at jointly and taking unit price given in the contract assigned to the successful Tenderer. In case of extra items where similar or com- parable items are quoted in the tender, extra rates shall be based on tender rates.
25. If the rate quoted by the contractor for any item / items are not workable or abnormally lower than the market rate, the bank may demand Bank guarantee from the contractor for satisfactory completion of these work. The bank guarantee amount will be not less than 50% of the estimated amount of the items for which the rates are not workable or abnormally low. This bank guarantee will be released after completion of these works (unworkable and abnormally low rated items) to the satisfaction of the bank.
26. The contractor shall submit the bar chart/CPM/PERT as well as shall submit the insurance cover for the work in the form of CAR policy and Third-Party Insurance within seven (7) days from the acceptance of work order.
27. The work must be started within immediately from the date of receipt of work order/ mark out at site; whichever is later. In case of work not being started within this stipulated period, the bank reserves the right to cancel the work order duly forfeiting the Earnest money deposit
28. No employee of the Bank is allowed to work as a contractor for a period of 2 years of his/her retirement from Bank Services without previous permission of the Bank. This contract is liable to be cancelled, if either the contractor or any of his employees is any time to be such a person who had not obtained the permission of Bank as aforesaid before submission of the tender or engagement in the contractor's service.
29. Contractor should get approval of the samples of materials in advance with Bank's Engineer be-fore use of the same in the work'
30. Bank has the right to offer the contract or to modify the old material wherever/whenever necessary instead of new supplies
31. The quoted rate should be inclusive of materials, labour, wages, fixtures, transportation, installation, all taxes(excluding GST), wastages, Octroi, machinery, temporary works such as scaffolding, cleaning, overheads, profit, statutory expenses, incidental charges and all related expenses to complete the work.
32. The tenders shall summarily have rejected, if any one of the above said requirements has not been complied with.
33. The Bank will not be bound to accept the lowest tender and reserves the right to accept or reject any or all the tenders without assigning any reason whatsoever
34. The contractor should fulfill the labour regulation guidelines stipulated by the governments

35. No advance payment in any form will be granted for the works proposed
36. Period of taking up the final bill will be one month from /after satisfactory virtual completion or the date of submission of the final bill whichever is later.
37. Contractor is advised not to engage child labour during the contract period
38. The SBI reserves the right to cancel or postpone the tenders at any stage without assigning any reason.
39. Firm should be visit the website till last date of submission for changes/corrigendum if any
40. Tender documents found partly or fully modified/alterd/corrected etc. shall stand summarily rejected
41. The make of materials should be chosen strictly from the approved makes as given in the tender .Using of the multi brands is not permissible. Single brand should be used for entire project.
42. ANY CLARIFCATIONS SOUGHT AFTER OPENING OF THE TENDERS WILL NOT BE ENTERTAINED AT ANY COST.

CHIEF MANAGER,  
STATE BANK OF INDIA

FORM OF SUBMISSION OF TENDER  
(To be filled by the tenderer)

The Chief Manager( Operations)  
State Bank of India,  
Regional Business Office.-IV, SBI BUILDING,Sharan wala Gate,  
The Mall,Patiala.-147001

Dear Sir/s,

REF: PROPOSED ELECTRICAL WORKS OF BRANCH AT SBI KHANAURI-50188 BRANCH IN PUNJAB.

I/We hereby declare that I/ We have carefully gone through the conditions laid down in the Notice Inviting Tender, General notes, General Conditions of Contract, Special conditions, Schedule of approximate quantities and rates, Form of Agreement, General Specification, Approved manufacturers/ natural source of materials Technical Specifications of schedule of quantities, and clearly understood all the same and on the basis of the same I/ We have quoted our rates in the Schedule of Quantities (i.e. BOQ) attached with the tender documents.

I / We do here by undertaken to execute and complete the whole or part of the work (as desired by you) at the respective rates quoted.

I/ We are depositing Earnest Money Deposit (Amounts as per NIT) by way of demand draft drawn in favor of **SBI, PATIALA** along with this tender for due execution of the work at my/ our tendered rates.

In the event of this Tender being accepted I/ We agree to enter into the agreement and submit the declaration on requisite non-judicial stamp papers as and when required and execute the contract according to your form of Agreement etc., in default whereof, I/ We do hereby bind my-self / ourselves to forfeit the aforesaid deposit.

In the event of this Tender being accepted I/ We agree to obtain the labor license and the CAR and Third party insurance policy and deposit the balance E.M.D. amount and adhere/comply to all other instructions as given in TENDER DOCUMENT.

I / We further agree to complete the work included in the said schedule of quantities as mentioned in NIT from the date of the work order issued to commence the same.

**Date of commencement shall be either three days from the date of work order issued to the contractor or the date on which mark out of work at site has been given to contractor; whichever is later.**

I/We agree not to employ sub-contractors other than those that may be approved by Employer.

I / We agree to pay all taxes(except GST), insurance charges as prevailing from time to time, on such items for whom same is to be levied by/ for the government, and the rates quoted by me / us are inclusive of all the same.

Yours Faithfully,  
Contractor's Signature\_\_  
Name:  
Address:

Signature of Witness:

- 1.
- 2.
- 3.

## GENERAL NOTES

### 1. PROCEDURE OF FILLING AND SUBMISSION OF TENDER

- a) Submission of BIDs/Tender Documents: Tenders should be submitted online in the website <https://www.tenderwizard.com/SBIETENDER>. In addition, scanned copy of the declaration to be signed with seal and scanned proof of valid dealership certificate should be submitted online with our service provider on the website at :<https://www.tenderwizard.com/SBIETENDER>.
- b) In the event of the tender being submitted by a firm, it must be signed by a member or members of the firm having legal authority to do so, and if called for, the legal documents in support thereof must be produced for inspection and the same in the case of the firm carried out by one member of a joint family. It must disclose that the firm is duly registered under the India Partner-ship Act. Any tender signed by a member not holding a power of attorney shall be treated as invalid.
- c) Tenderer shall note that their tenders shall remain open for acceptance for a minimum period of three months from the last date of receipt of tenders. The tenders must be unconditional. Conditional tenders may be summarily rejected.

### 2. RATES TO INCLUDE:

While quoting their rates the tenderer should include the following if otherwise not stated herein be-fore.

- a) Necessary cost of taking samples of materials supplied by them for the work, testing of the same at Govt.'s / approved laboratory including transportation, cost of the samples, as and when required.
- b) Submission of test reports of other materials as may be specified by Bank's Engineer/Architect.

### 3. STORAGE OF MATERIALS:

The contractor shall not store their materials and debris within the premises other than the work site handed over to him.

### 5. LABOUR HUTMENT:

Shelter or stay and other amenities for the labors have to be arranged by the contractor at his own expense and responsibility (outside the Bank premises).

### 6. IDLE LABOUR:

In case the work is held up for any site conditions not attributable to the contractors or for any decisions instructions / want of details from Employer or for any of the conditions, the contractor shall be allowed reasonable extension of time by the employer but any claim for idle labour shall not be entertained by the employer. Contractor's quoted rates should include for all such contingencies.

7. The contractor shall engage one competent person at site who shall take the instructions from the Employer. The work should not suffer due to lack of supervision, man power and materials.

8. The Contractor is required to co-ordinate his works along with other agencies working at site. He has to reimburse any of the damage made by him or any of his representatives for any of the other agency or owner at site.

9. Making of any cut-out / opening for electrical wiring / fitting in any of false ceiling, partition, Paneling, masonry work etc., and providing panels of the same finish in partitions, paneling shall not be paid extra.
10. The contractor is required to fabricate a sample where required, or any item so installed for approval. Any changes made by the Architect/Employer, in the sample to the specifications as mentioned in the tender, shall not be deducted or paid extra.
11. All measurements given in the schedule hereunder are for the purpose of tender only. Payment will be made on actual measurement of the work done.
12. All measurements shall be as per relevant I.S .standards

LETTER OF UNDERTAKING (Annexure I)

*(The bidders are required to print this on their company's letter head and sign, stamp before emailing)*

To,  
The Chief Manager( Operations)  
State Bank of India,  
Regional Business Office.-IV, SBI BUILDING,Sharan wala Gate,  
The Mall,Patiala.-147001.  
Dear Sir,

Having examined the drawings, specification, design and schedule of quantities relating to the works specified in the memorandum hereinafter set out and having visited and examined the site of the works specified in the said memorandum and having acquired the requisite information relating thereto as affecting the tender, I/We hereby offer to execute the works specified in the said memorandum at the rates mentioned in the attached Schedule of Quantities and in accordance in all respects with the specifications, design, drawings and instructions in writing referred to in conditions of tender, the Articles of Agreement, Special Conditions, Schedule of Quantities and Conditions of Contract and with such materials as are provided for by, and in all other respects in accordance with such conditions so far as they may be applicable.

MEMORANDUM

(a)	Description of work	E-TENDER FOR <u>ELECTRICAL WORKS OF BRANCH &amp; E-LOBBY AT STATE BANK OF INDIA, KHANAURI.-50188(PB.)</u>
(b)	Earnest Money	<b>Rs.11,650/- (Rupees Eleven Thousand six hundred fifty Only)</b> by means of Demand Draft / Pay Order (Valid for a period of completion of the work from the last date of submission of the tender) from any scheduled Nationalized Bank drawn in favour of SBI and payable in <b>PATIALA.</b>
(c)	Time allowed for completion of the Works from Seven day after the date of written Order or date of handing over of the site (Whichever is later) to commence the work	<b>60 days</b>

- 1) Should this tender be accepted, I/we here by agree to abide by and fulfill the terms and provisions of the said conditions of contract annexed hereto so far as may be applicable or in default thereof to forfeit and pay to SBI, the amount mentioned in the said contract.
- 2) I / We have deposited a sum of **Rs.11,650/- (Rupees Eleven Thousand six hundred fifty Only)** amount is not to bear any interest . I/We fail to execute the Contract when called upon to do so I / We do hereby agree that this sum shall be forfeited by me/us to SBI.
- 3) I/ We have read and understood various clauses of this tender and hereby submit our specific undertaking and concurrence in terms clause of "Instruction to tenderer" to deposit *Additional Security Deposit (ASD)* of required amount as provided for in this

tender and within the stipulated period, in case, my/our tender is found too low (i.e. beyond 7.5% of the estimated cost) ,as a performance guarantee for due fulfillment of our contractual obligation for the project.

Further, under any circumstances, whatsoever, if I/We fail to comply the same including compliance of any such other conditions of tender within the stipulated time. I /We hereby, authorized SBI to cancel my/our tender, to forfeit my EMD/ISD/ASD and to take further necessary action as deemed fit including debarring our firm from participating in SBI future tenders/de-paneling etc.

- 4) I/ We understand that as per terms of this tender, the SBI may consider accepting our tender in part or whole or may entrust the various work proposed in phases. We, therefore, undertake that we shall not raise any claim/ compensation in the eventuality of Bank deciding to drop any of the work from the scope of work of this tender at any stage during the contract period. Further, we also undertake to execute the work entrusted to us in phases on our approved rates and within stipulated time limit without any extra claim for price escalation as also provided for in the clause of "Instructions to Tenderers" of this tender.
- 5) I/ We, hereby, also undertake that, we will not raise any claim for any escalation in the prices of any of the material during the currency of contract/execution/completion period including authorized extended contract period, if any.

6) Our Bankers are

- i)
- ii)

The names of partners of our firm are:

- i)
- ii)

Name of the partner of the firm Authorized to sign

Or

(Name of person having Power of Attorney to sign the Contract.

(Certified true copy of the Power of Attorney should be attached)

Yours faithfully,  
Signature of Contractors.  
Signature and addresses of Witnesses

- i)
- ii)

## GENERAL CONDITIONS OF CONTRACT

### 1.0 Definitions: -

“Contract means the documents forming the tender and the acceptance there of and the formal agreement executed between SBI (client) and the Contractor/ Vendor, together with the documents referred there in including these conditions, the specifications, designs, drawings and instructions issued from time to time by the Bank and all these documents taken together shall be deemed to form one contract and shall be complementary to one another.

1.1 In the contract the following expressions shall, unless the context otherwise requires, have the meaning hereby respectively assigned to them.

1.1.1 “SBI” shall mean State Bank of India (Client) having its Corporate Centre at Madame Cama Road, Nariman Point, Mumbai- 400 021 and its representative Local HeadOffices/Administrative Offices/Regional Business Offices/Branches at various places across India and includes the client’s representatives, successors and assigns.

1.1.2 ‘The Contractor/ Vendor’ shall mean the individual or firm or company undertaking the works and shall include legal personal representative of individual or composing the firm or company and the permitted assignees of individual or firms of company.

1.1.3 The expression ‘works’ or ‘work’ shall mean the permanent or temporary work description in the “Scope of work” and / or to be executed in accordance with the contract includes materials, apparatus, equipment, temporary supports, fittings and things of kinds to be provided, the obligations of the Contractor/ Vendor hereunder and work to be done by the Contractor/ Vendor under the contract.

1.1.4 Engineer’ shall mean the representative Civil / Electrical Engineer of the SBI

1.1.5 ‘Drawings’ shall mean the drawings prepared and issued by SBI or their Architects and referred to in the specifications and any modifications of such drawings as may be issued by the Engineer from time to time.

1.1.6 ‘Contract value shall mean value of the entire work as stipulated in the letter of acceptance of tender subject such additions thereto or deductions there from as may be made under the provide herein after contained.

1.1.7 Specifications’ shall mean the specifications referred to in the tender and modifications thereof as may time to time be furnished or approved by the SBI

1.1.8 “Month” means calendar month.

1.1.9 “Week” means seven consecutive days.

1.1.10 “Day” means a calendar day beginning and ending at 00 Hrs. and 24 Hrs. respectively.

1.1.11 SBI's Engineer" shall mean The Civil / Electrical Engineer in - charge of the Project.

## 2.0 CLAUSE

1.0 Total Security Deposit: The Total Security deposit comprise of

- a) Earnest Money Deposit
- b) Initial security deposit
- c) Retention Money

### a) Earnest Money Deposit -

The tenderer shall furnish EMD of **Rs.11,650/- (Rupees Eleven Thousand six hundred fifty Only)** in the form of Demand draft drawn in favor of SBI on any Scheduled Bank. No tender shall be considered unless the EMD is deposited in the required form.

- No interest shall be paid on this EMD. The EMD of the unsuccessful tenderer shall be refunded soon after the decision to award the contract is taken without interest.
- The EMD shall stand absolutely forfeited if the tenderer revokes his tender at any time the period when he is required to keep his tender open acceptance by the SBI or after it is accepted by the SBI. the Contractor/ Vendor fails to enter into a formal agreement or fails to pay the initial security deposit as stipulated or fails to commence the commence the work within the stipulated time.

### b) Initial Security Deposit (ISD)

The amount of ISD shall be 2% of accepted value of tender (In the instant case, the cumulative contract awarded value of including the EMD in the form of DD drawn on any scheduled Bank. The DD shall be deposited within 7 days from the date of acceptance of tender.

### c) Retention Money: -

An amount @ 5% of the bill amount will be retained by the SBI from the bills and the same will be released by the SBI against Bank guarantee for equal amount issued by any Nationalised /Scheduled Bank in the SBI's approved format valid for 1 year. The Bank guarantee shall be released only after completion of warranty period of 1 year provided no complaint is received in the office chairs or the defects has been rectified by replacing the same satisfactorily.

*The successful bidder may choose to submit such Bank Guarantee to the SBI soon after commencement of work to avoid deduction of retention money from the Bills. No advance on materials / plant / machinery or mobilization advance shall be paid in any circumstances.*

## 2.0 Language

The language in which the contract documents shall be drawn shall be in English.

## 2.0 Errors, Omissions and discrepancies

In case of errors, omissions and/ or disagreement between written and scaled dimensions on the drawings or between the drawings and specifications etc., the following order shall apply.

- i) Between scaled and written dimension (or description) on a drawing, the latter shall be adopted.
- ii) Between the written or shown description or dimensions in the drawings and the corresponding one in the specification the former shall be taken as correct.
- iii) Between written description of the item in the specifications and descriptions in bills of quantities of the same item, the former shall be adopted:
  - a) In case of difference between rates written in figures and words, the rate in words shall prevail.
  - b) Between the duplicate / subsequent copies of the tender, the original tender shall be taken as correct.

## 4.0 Scope of Work:

The Contractor/ Vendor shall carry out, complete and maintain the said work in every respect strictly accordance with this contract and with the directions of and to the satisfaction of the Bank to be communicated through SBI. The SBI at the direction of the Bank from time to time issue further drawings and / or written instructions, detailed directions and explanations which are hereafter collectively referred to as instructions in regard to the variation or modification of the design, quality or quantity of any work or the addition or omission or substitution work. Any discrepancy in the drawings or between BOQ and / or drawings and / or specifications should be brought to the notice of SBI immediately. The removal from the site of any material brought thereon by the Contractor/ Vendor and any substitution of any other materials therefore the removal and / or re-executed of any work executed by him. The dismissal from the work of any person engaged thereupon.

## 5.0 i) Letter of Acceptance:

Within the validity period of the tender the SBI shall issue a letter of acceptance directly by registered post or otherwise depositing at the office of the Contractor/ Vendor as given in the tender to enter into a Contract for the execution of the work as per the terms of the tender. The letter of acceptance shall constitute a binding contract between the SBI and the Contractor/ Vendor.

## ii) Contract Agreement:

On receipt of intimation of the acceptance of tender from the SBI. The successful tenderer shall be bound to implement the contract and within 15 days there of shall sign an agreement in a non-judicial stamp paper of appropriate value.

**6.0 Ownership of drawings:**

All drawings, specifications and copies thereof furnished by the SBI are the properties of the SBI. They are not to be used on other work.

**7.0 Detailed drawings and instructions:**

The SBI shall furnish with reasonable proper additional instructions by means of drawings or otherwise necessary for the execution of the work. All such drawings and instructions shall be consistent with contract documents, true developments thereof and reasonably inferable there.

The work shall be executed in conformity therewith and the Contractor/ Vendor prepare a detailed program schedule indicating therein the date of start and completion of various activities on receipt of the work order and submit the same to the SBI through the architect/consultant

**7.0 Copies of agreement**

Two copies of agreement duly signed by both the parties with the drawings shall be handed over to the Contractor/ Vendors.

**8.0 Liquidated damages:**

If the Contractor/ Vendor fails to maintain the required progress in terms of relevant clause under General Conditions of Contract (GCC) or to complete the work and clear the site including vacating their office on or before the contracted or extended date or completion, without justification in support of the cause of delay, he may be called upon without prejudice to any other right of remedy available under the law to the SBI on account of such breach to pay a liquidated damage at the rate of 0.50% of the contract value subject to a maximum of 5% of the contract value.

**9.0 Materials, Appliances and Employees**

Unless or otherwise specified the Contractor/ Vendor shall provide and pay for all materials, labour, water, power, tools, equipment transportation and any other facilities that are required for the satisfactory execution and completion of the work. Unless or otherwise specified all materials shall be new and both workmanship and materials shall be best quality. The Contractor/ Vendor shall at all times enforce strict discipline and good order among his employees and shall not employ on the work any unfit person or anyone not skilled in the work assigned to him. Workman whose work or behavior is found to be unsatisfactory by the SBI he shall be removed from the site immediately.

**10.0 Permits, Laws and Regulations:**

Permits and licenses required for the execution of the work shall be obtained by the Contractor/ Vendor at his own expenses. The Contractor/ Vendor shall give notices and comply with the regulations, laws, and ordinances rules, applicable to the contract. If the Contractor/ Vendor observes any discrepancy between the drawings and specifications, he shall promptly notify the SBI in writing. If the Contractor/ Vendor performs any act, which is against the law, rules and regulations he shall meet all the costs arising there from and shall

indemnify the SBI any legal actions arising there from.

#### 11.0 Setting out Work:

The Contractor/ Vendor shall set out the work and shall be responsible for the true and perfect setting out of the same and for the correctness of the positions, levels, dimensions, and alignment of all parts thereof and get it approved by the SBI before proceeding with the work. If at any time any error in this respect shall appear during the progress of the works, irrespective of the fact that the layout had been approved by SBI, the Contractor/ Vendor shall be responsible for the same and shall his own expenses rectify such error, if so, required to satisfaction of the SBI.

#### 12.0 Protection of works and property:

The Contractor/ Vendor shall continuously maintain adequate protection of all his work from damage and shall protect the SBI's properties from injury or loss arising in connection with contract. He shall make good any such damage, injury, loss, except due to causes beyond his control and due to his fault or negligence.

He shall take adequate care and steps for protection of the adjacent properties. The Contractor/ Vendor shall take all precautions for safety and protections of his employees on the works and shall comply with all applicable provisions of Govt. and local bodies' safety laws and building codes to prevent accidents, or injuries to persons or property on about or adjacent to his place of work. The Contractor/ Vendor shall take insurance covers as per clause 24.0 at his own cost. The policy may be taken in joint names of the Contractor/ Vendor and the SBI and the original policy may be lodged with the SBI.

#### 13.0 Inspection of work:

The SBI or their representatives shall at all reasonable times have free access to the work site and / or to the workshop, factories, or other places where materials are lying or from where they are obtained and the Contractor/ Vendor shall give every facility to the SBI and their representatives necessary for inspection and examination and test of the materials and workmanship. No person unless authorized by the SBI except the representative of Public authorities shall be allowed on the work at any time. The proposed work either during its construction stage or its completion can also be inspected by the Chief Technical Examiner's Organization a wing of Central Vigilance commission.

#### 14.0 Assignment and subletting

The whole of work included in the contract shall be executed the Contractor/ Vendor and he shall not directly entrust and engage or indirectly transfer, assign or underlet the contract or any part or share thereof or interest therein without the written consent of the SBI and no undertaking shall relieve the Contractor/ Vendor from the responsibility of the Contractor/ Vendor from active & superintendence of the work during its progress.

#### 15.0 Quality of materials, workmanship & Test

All materials and workmanship shall be best of the respective kinds as described in the contract/BOQ and in accordance with SBI's instructions and shall be subject from time to time to such tests as the SBI. may direct at the place of manufacture or fabrication or on the

site or an approved testing laboratory. The Contractor/ Vendor shall provide such assistance, instruments, machinery, labor, and materials as are normally required for examining measuring sampling and testing any material or part of work before incorporation in the work for testing as may be selected and required by the SBI.

**ii) Samples**

All samples of adequate numbers, size, shades & pattern as per specifications shall be supplied by the Contractor/ Vendor without any extra charges. If certain items proposed to be used are of such nature that samples cannot be presented or prepared at the site detailed literature / test certificate of the same shall be provided to the satisfaction of the SBI. Before submitting the sample / literature the Contractor/ Vendor shall satisfy himself that the material/ Equipment for which he is submitting the sample / literature meet with the requirement of tender specifications. Only when the samples are approved in writing by SBI the Contractor/ Vendor shall proceed with the procurement and installation of the particular material / equipment. The approved samples shall be signed by SBI for identification and shall be kept on record at site office until the completion of the work for inspection / comparison at any time. SBI shall take reasonable time to approve the sample. Any delay that might occur in approving the samples for reasons of its not meeting the specifications or other discrepancies inadequacy in ELECTRICAL samples of best qualities from various manufacturers and such other aspects causing delay on the approval of the materials / equipment etc. shall be to the account of the Contractor/ Vendor.

**iii) Cost of tests**

The cost of making any test shall be borne by the Contractor/ Vendor if such test is intended by or provided for in the specification or BOQ.

**16.0 Obtaining information related to execution of work**

No claim by the Contractor/ Vendor for additional payment shall be entertained which is consequent upon failure on his part to obtain correct information as to any matter affecting the execution of the work nor any misunderstanding or the obtaining incorrect information or the failure to obtain correct information relieve him from any risks or from the entire responsibility for the fulfillment of contract.

**17.0 Contractor/ Vendor's superintendence**

The Contractor/ Vendor shall give necessary personal superintendence during the execution the works and as long, thereafter, as the SBI may consider necessary until the expiry of the defects liability period, stated here to.

**18.0 Quantities**

The bill of quantities (BOQ) unless or otherwise stated shall be deemed to have been prepared in accordance with the Indian Standard Method of Measurements and quantities. The rate quoted shall remain valid for variation of quantity against individual item to any extent.

**19.0 Works to be measured**

SBI may from time to time intimate to the Contractor/ Vendor that the work is required to be measured and the Contractor/ Vendor shall forthwith attend or send a qualified

representative to assist the SBI in taking such measurements and calculation and to furnish all particulars or to give all assistance required by any of them. Such measurements shall be taken in accordance with the Mode of measurements detail in the specifications. The representative of SBI shall take measurements with the Contractor/ Vendor's representative and the measurements shall be entered in the measurement book. The Contractor/ Vendor or his authorized representative shall sign all the pages of the measurement book in which the measurements have been recorded in token of his acceptance. All the corrections shall be duly attested by both representatives. No over writings shall be made in the Measurement book should the Contractor/ Vendor not attend or neglect or omit to depute his representative to take measurements the measurements recorded by the representative of the SBI shall be final. All authorized extra work, omissions and all variations made shall be included such measurement.

## 20.0 Variations

No alteration, omission or variation ordered in writing by SBI vitiates the contract. In case the SBI thinks proper at any stage during the progress of works to make any alteration in, or additions to or omission from the works or any. alteration in the kind or quality of the materials to be used therein, the SBI shall give notice thereof in writing to the Contractor/ Vendor shall confirm in writing within seven days of giving such oral instructions the contract shall alter to, add to, or omit from as the case may be in accordance with such notice but the Contractor/ Vendor shall not do any work extra to or make any alterations or additions to or omissions from the works or any deviation from any of the provisions of the contract, stipulations, specifications or contract drawings without previous consent in writing of the SBI and the value of such extras, alterations, additions or omissions shall in all cases be determined by the SBI and the same shall be added to or deducted from the contract value, as the case may be.

## 21.0 Valuation of Variations

No claim for an extra Item shall be allowed unless it shall have been executed under the authority of the SBI with the concurrence of the SBI as herein mentioned. Any such extra is herein referred to as authorized extra and shall be made in accordance with the following provisions.

- a)
  - (i) The net rates or prices in the contract shall determine the valuation of the extra work where such extra work is of similar character and executed under similar conditions as the work priced herein.
  - (ii) Rates for all items, wherever possible should be derived out of the rates given in the priced BOQ.
- b) The net prices of the original tender shall determine the value of the items omitted, provided if omissions do not vary the conditions under which any remaining items of Works are carried out, otherwise the prices for the same shall be valued under subClause 'c' hereunder.
- c) Where the extra works are not of similar character and/or executed under similar conditions as aforesaid or where the omissions vary the conditions under which any remaining items or works are carried out, then the Contractor/ Vendor shall within 7 days of the receipt of the letter of acceptance inform the SBI of the rate which he intends to charge for such items of work, duly supported by analysis of the rate or rates claimed and the SBI shall fix such rate or prices as in the circumstances in its opinion are reasonable and proper, based on the market rate.

- d) Where extra work cannot be properly measured or valued the Contractor/ Vendor shall be allowed day work prices at the net rates stated in the tender, of the BOQ or, if not, so stated then in accordance with the local day work rates and wages for the district; provided that in either case, vouchers specifying the daily time (and if required by the SBI) the workman's name and materials employed be delivered for verifications to the Architect /consultant at or before the end of the week following that in which the work has been executed.
- e) It is further clarified that for all such authorized extra items where rates cannot be derived from the tender, the Contractor/ Vendor shall submit rates duly supported by rate analysis worked on the 'market rate basis for material, labour hire / running charges of equipment and wastages etc. plus 15% towards establishment charges, Contractor/ Vendor's overheads and profit. Such items shall, not be eligible for escalation.

## **22.0 Final measurement**

The measurement and valuation in respect of the contract shall be completed within one months of the virtual completion of the work.

## **23.0 Virtual Completion Certificate (VCC)**

On successful completion of entire works covered by the contract to the full satisfaction of the SBI, the Contractor/ Vendor shall apply to SBI for completion certificate.

Upon the satisfactory fulfillment by the Contractor/ Vendor as stated above, the Contractor/ Vendor is entitled to apply to the SBI of satisfactory completion of work. Relative to which the completion certificate has been sought, the SBI shall within fourteen (14) days of the receipt of the application for completion certificate, issue a VCC in respect of the work for which the VCC has applied.

This issuance of a VCC shall not be without prejudice to the SBI's rights and Contractor/ Vendor liabilities under the contract including the Contractor/ Vendor's liability for defects liability nor shall the issuance of VCC in respect of the works or work at any site be construction as a waiver of any right or claim of the SBI against the Contractor/ Vendor in respect of or work at the site and in respect of which the VCC has been issued.

#### **24.0 Insurance of works**

24.1 Without limiting his obligations and responsibilities under the contract the Contractor/ Vendor shall insure in the joint names of the SBI and the Contractor/ Vendor against all loss of damages from whatever cause arising other than the excepted risks, for which he is responsible under the terms of contract and in such a manner that the SBI and Contractor/ Vendor are covered for the period stipulated in clause 28 of GCC and are also covered during the period of maintenance for loss or damage arising from a cause, occurring prior to the commencement of the period of maintenance and for any loss or damage occasioned by the Contractor/ Vendor in the course of any operations carried out by him for the purpose of complying with his obligations under clause.

- a) The Works for the time being executed to the estimated current Contract value thereof, or such additional sum as may be specified together with the materials for incorporation in the works at their replacement value.
- b) Such insurance shall be affected with an insurer and in terms approved by the SBI which approval shall not be unreasonably withheld and the Contractor/ Vendor shall whenever have required produce to the SBI the policy of insurance and the receipts for payment of the current premiums.

#### **25.0 Damage to persons and property**

The Contractor/ Vendor shall, except if and so far as the contract provides otherwise indemnify the SBI against all losses and claims in respect of injuries or damages to any person or material or physical damage to any property whatsoever which may arise out of or in consequence of the execution and maintenance of the works and against all claims proceedings, damages, costs, charges and expenses whatsoever in respect of or in relation thereto except any compensation of damages for or with respect to:

- a) The permanent use or occupation of land by or any part thereof.
- b) The right of SBI to execute the works or any part thereof on, over, under, in or through anylands.

- c) Injuries or damages to persons or properties which are unavoidable result of the execution or maintenance of the works in accordance with the contract
- d) Injuries or damage to persons or property resulting from any act or neglect of the SBI their agents, employees or other Contractor/ Vendors not being employed by the Contractor/ Vendor or for or in respect of any claims, proceedings, damages, costs, charges and expenses in respect thereof or in relation thereto or where the injury or damage was contributed to by the Contractor/ Vendor, his servants or agents such part of the compensation as may be just and equitable having regard to the extent of the responsibility of the SBI, their employees, or agents or other employees, or agents or other Contractor/ Vendors for the damage or injury.

#### **26.0 Contractor/ Vendor to indemnify SBI**

The Contractor/ Vendor shall indemnify the SBI against all claims, proceedings, damages, costs, charges and expenses in respect of the matters referred to in the provision sub-clause 25 of this clause.

#### **27.0 Contractor/ Vendor's superintendence**

The Contractor/ Vendor shall fully indemnify and keep indemnified the SBI. against any action, claim, or proceeding relating to infringement or use of any patent or design or any alleged patent or design rights and shall pay any royalties which may be payable in respect of any article or part thereof included in the contract. In the event of any claim made under or action brought against SBI. in respect of such matters as aforesaid the Contractor/ Vendor shall be immediately notified thereof and the Contractor/ Vendor shall be at liberty, at his own expenses to settle any dispute or to conduct any litigation that may arise there from, provided that the Contractor/ Vendor shall not be liable to indemnify the SBI. if the infringement of the patent or design or any alleged patent or design right is the direct result of an order passed by the SBI in this behalf.

#### **28.0 Third Party Insurance**

28.1 Before commencing the execution of the work the Contractor/ Vendor but without limiting his obligations and responsibilities under clause 24.0 of GCC shall insure against his liability for any material or physical damage, loss, or injury which may occur to any property including that of SBI., or to any person, including any employee of the SBI, by or arising out of the execution of the works or in the carrying out of the contract, otherwise than due to the matters referred to in the provision to clause 24.0 thereof.

#### **28.2 Minimum amount of Third Party Insurance**

Such insurance shall be affected with an insurer and in terms approved by the SBI whose approval shall not be reasonably withheld and for at least the amount stated below. The Contractor/ Vendor shall, whenever required, produce to the SBI the policy or policies of insurance cover and receipts for payment of the current premiums.

The minimum insurance cover for physical property, injury, and death is Rs.5 Lakh per occurrence with the number of occurrences limited to four. After each occurrence Contractor/ Vendor will pay additional premium necessary to make insurance valid for four occurrences always.

**29.0 Accident or Injury to workman:**

- i. The SBI shall not be liable for or in respect of any damages or compensation payable at law in respect or in consequence of any accident or injury to any workmen or other person in the employment of the Contractor/ Vendor or any sub-Contractor/ Vendor, save and except an accident or injury resulting from any act or default of the SBI or their agents, or employees. The Contractor/ Vendor shall indemnify and keep indemnified SBI against all such damages and compensation, save and except as aforesaid, and against all claims, proceedings, costs, charges and expenses whatsoever in respect thereof or in relation thereto.

- ii. Insurance against accidents etc. to workmen

The Contractor/ Vendor shall insure against such liability with an insurer approved by the SBI during the whole of the time that any persons are employed by him on the works and shall, when required, produce to the architect / consultant such policy of insurance and receipt for payment of the current premium. Provided always that, in respect of any persons employed by any sub Contractor/ Vendor the Contractor/ Vendor's obligation to insure as aforesaid under this sub-clause shall be satisfied if the sub-Contractor/ Vendor shall have insured against the liability in respect of such persons in such manner that SBI is indemnified under the policy but the shall require such sub-Vendor to produce to the SBI when such policy of insurance and the receipt for the payment of the current premium.

- iii. Remedy on Contractor/ Vendor's failure to insure

If the Contractor/ Vendor fails to effect and keep in force the insurance referred to above or any other insurance which he may be required to effect under the terms of contract, then and in any such case the SBI may effect and keep in force any such insurance and pay such premium or premiums as may be necessary for that purpose and from time to time deduct the amount so paid by the SBI as aforesaid from any amount due or which may become due to the Contractor/ Vendor or recover the same as debt from the Contractor/ Vendor.

- iv. Without prejudice to the others rights of the SBI against Contractor/ Vendors. In respect of such default, the employer shall be entitled to deduct from any sums payable to the Contractor/ Vendor the amount of any damages costs, charges and other expenses paid by the SBI and which are payable by the Contractor/ Vendors under this clause. The Contractor/ Vendor shall upon settlement by the Insurer of any claim made against the insurer pursuant to a policy taken under this clause, proceed with due diligence to rebuild or repair the works destroyed or damaged. In this event all the monies received from the Insurer in respect of such damage shall be paid to the Contractor/ Vendor and the Contractor/ Vendor shall not be entitled to any further payment in respect of the

expenditure incurred for rebuilding or repairing of the materials or goods destroyed or damaged.

### 30.0 Commencement of Works:

The date of commencement of the work will be reckoned as the date of execution of agreement with SBI or possession of site which ever is later.

### 31.0 Time for completion

Time is essence of the contract and shall be strictly observed by the Contractor/ Vendor. The entire work shall be completed within a period of **60 Days** from the date of commencement.

### 32.0 Extension of time

If, the work be delayed for reasons beyond the control of the Contractor/ Vendor, the Contractor/ Vendor may submit a recommendation to the SBI to grant a fair and reasonable extension of time for completion of work as per the terms of contract. If the Contractor/ Vendor needs an extension of time for the completion of work or if the completion of work is likely to be delayed for any reasons beyond the due date of completion as stipulated in the contract, the Contractor/ Vendor shall apply to the SBI. in writing at least 30 Days before the expiry of the scheduled time and while applying for extension of time he shall furnish the reason in detail and his justification if any, for the delays in the prescribed format for granting extension of time. While granting extension of time the Contractor/ Vendor shall be informed the period extended time which will qualify for levy of liquidated damages. For the balance period in excess of original stipulated period and duly sanctioned extension of time by the provision of liquidated damages as stated under clause 8.0 shall become applicable. Further the contract shall remain in force even for the period beyond the due date of completion irrespective whether the extension is granted or not.

### 33.0 Rate of progress

Whole of the materials, plant and labour to be provided by the Contractor/ Vendor and the mode, manner and speed of execution and maintenance of the works are to be of a kind and conducted in a manner to the satisfaction of the SBI. Should the rate of progress of the work or any part thereof be at any time be in the opinion the SBI too Slow to ensure the completion of the whole of the work the prescribed time or extended time for completion, the SBI shall thereupon take such steps as considered necessary to expedite progress so as to complete the works by the prescribed time or extended time. Such communications from the SBI neither shall relieve the Contractor/ Vendor from fulfilling obligations under the contract nor will he be entitled to raise any claims arising out of such directions.

### 34.0 Work during nights and holidays

Subject to any provision to the contrary contained in the contract no permanent work shall, as herein provided, be carried on during the night or on holidays without the permission in writing of the SBI, except when the work is unavoidable or absolutely necessary for the

saving of life or property or for the safety of the work in which case the Contractor/ Contractor/ Vendor shall immediately advise the SBI. However, the provisions of the clause shall not be applicable in the case of any work which becomes essential to carry by rotary or double shifts in order to achieve the progress and quality of the part of the works being technically required / continued with the prior approval of the SBI at no extra cost.

All work at night after obtaining approval from competent authorities of SBI shall be carried out without unreasonable noise and disturbance.

### 35.0 No compensation or restrictions of work

If at any time after acceptance of the tender, SBI shall decide to abandon or reduce the scope of work for any reason whatsoever and hence not required the whole or any part of the work to be carried out. SBI shall give notice in writing to that effect to the Contractor/ Vendor and the Contractor/ Vendor shall act accordingly in the matter. The Contractor/ Vendor shall have no claim to any payment of compensation or otherwise whatsoever on account of any profit or advantage which he might have derived from the execution of the Work fully but which he did not derive in consequence of the foreclosure of the whole or part of the work.

Provided that the Vendor shall be paid the charges on the cartage of only materials actually and bona-fide brought to the site of the work by the Contractor/ Vendor and rendered surplus as a result of the abandonment, curtailment of the work or any portion thereof and then taken back by the Vendor, provided however that the SBI shall have in such cases the option of taking over all or any such materials at their purchase price or a local current rate whichever is less.

"In case of such stores having been issued from SBI stores and returned by the Vendor to stores, credit shall be given to him at the rates not exceeding those at which were originally issued to the Vendor after taking into consideration and deduction for claims on account of any deterioration or damage while in the custody of the Contractor/ Vendor and in this respect the decision of Architect / consultant shall be final.

### 36.0 Suspension of work

- i) The Contractor/ Vendor shall, on receipt of the order in writing of SBI (whose decision shall be final and binding on the Contractor/ Vendor) suspend the progress of works or any part thereof for such time and in such manner as SBI may consider necessary so as not to cause any damage or injury to the work already done or endanger the safety thereof for any of following reasons:
  - a) On account any default on the part of the Contractor/ Vendor, or
  - b) For proper execution of the works or part thereof for reasons other than the default the Vendor/ Contractor, or
  - c) For safety of the works or part thereof.

The Contractor / Vendor shall, during such suspension, properly protect and secure the works the extent necessary and carry out the instructions given in that behalf by the SBI.

- ii) If the suspension is ordered for reasons (b) and (c) in sub-para (i) above:

The Contractor/ Vendor shall be entitled to an extension of time equal to the period of every such suspension. No compensation whatsoever shall be paid on this account.

### 37.0 Action when the whole security deposit is forfeited

In any case in which under any clause or clauses of this contract, the Contractor/ Vendor shall have rendered himself liable to pay compensation amounting to the whole of his security deposit the SBI shall have the power to adopt any of the following course as they may deem best suited to the interest of the SBI:

- a) To rescind the contract (of which rescission notice in writing to the Contractor/ Vendor by SBI shall be conclusive evidence) and in which case the security, deposit of the Contractor/ Vendor shall be forfeited and be absolutely at the disposal of SBI
- b) To employ labour paid by the SBI and to supply materials to carry out the work, or part of the work, debiting the Contractor/ Vendor with the cost of the labour and materials cost of such labour and materials (as worked out by the SBI shall final and conclusive against the Contractor/ Vendor) and crediting him with the value of the work done, in all respects in the same manner and at the same manner and at the same rates as if it had been carried out by the Contractor/ Vendor under the terms of this contract certificate of SBI as to the value of work done shall be final conclusive against the Contractor/ Vendor.
- c) To measure up the work of the Contractor/ Vendor, and to take such part thereof as shall be unexecuted, out of his hands, and to give it to another Contractor/ Vendor to complete, in which case any expenses which may be incurred in excess of the sum which would have been paid to the original Contractor/ Vendor, if the whole work had been executed by him ( The amount of which excess the certificates in writing of the SBI shall final and conclusive) shall be borne by original Contractor/ Vendor and may be deducted if any money due to him by SBI under the contract or otherwise, or from his security deposit or the proceeds of sale thereof, or sufficient part thereof.

In the event of any of above courses being adopted by the SBI the Contractor/ Vendor shall have no claim to compensation for any loss sustained by him by reasons of his having purchased or procured any material or entered into any engagements or make any advances on account of, or with a view to the execution of the work or the performance of the contract and in case the contract shall be rescind under the provision aforesaid, the Contractor/ Vendor shall not be entitled to recover or to be paid any sum or any work thereto for actually performed under this contract, unless, and until SBI will have certified in writing the performance of such work and the value payable in respect thereof, and he shall only be entitled to be paid the value so certified.

### 38.0 Owner's right to terminate the contract

If the Contractor/ Vendor being an individual or a firm commit any 'Act of insolvency' or shall be adjusted an insolvent or being an incorporated company shall have an order for

compulsory winding up voluntarily or subject to the supervision of Govt. and of the Official Assignee of the liquidator in such acts of insolvency or winding up shall be unable within seven days after notice to him to do so, to show to the reasonable satisfaction of the SBI that he is able to carry out and fulfill the contract, and to dye security therefore if so required by the SBI

Or if the Contractor/ Vendor (whether an individual firm or incorporated Company) shall suffer execution to be issued or shall suffer any payment under this contract to be attached by or on behalf of any of the creditors of the Contractor/ Vendor.

Or shall assign or sublet this contract without the consent in writing of the SBI or shall charge or encumber this contract or any payment due to which may become due to the Contractor/ Vendor there under:

- a) has abandoned the contract; or
- b) has failed to commence the works or has without any lawful excuse under these conditions suspended the progress of the works for 14 days after receiving from the SBI written notice to proceed, or
- c) *has failed to proceed with the works with such diligence and failed to make such due progress as would enable the works to be completed within the time agreed upon, or has failed to remove the materials from the site or to pull down and replace work within seven days after written notice from the SBI that the said materials were condemned and rejected by the SBI under these conditions; or has neglected or failed persistently to observe and perform all or any of the acts matters or things by this contract to be observed and performed by the contractor for seven days after written notice shall have been given to the Contractor/ Vendor to observe or perform the same or has to the detriment of good workmanship or in defiance of the SBI to the contrary subject any part of the contract.*

Then and in any of said cases the SBI may notwithstanding any previous waiver, after giving seven days' notice in writing to the Contractor/ Vendor, determine the contract, but without thereby affecting the powers of the SBI or the obligation and liabilities of the Contractor/ Vendor the whole of which shall continue in force as fully as if the contract had not been determined and as if the works subsequently had been executed by or on behalf of the Contractor/ Vendor. And, further the SBI or their employees may enter upon and take possession of the work and all plants, tools, scaffoldings, materials, sheds, machineries lying upon the premises or on the adjoining lands or roads use the same by means of their own employees or workmen in carrying on and completing the work or by engaging any other Contractor/ Vendors or persons to the work and the Contractor/ Vendor shall not in any way interrupt or do any act, matter or thing to prevent or hinder such other Contractor/ Vendor or other persons employed for complement and finishing or using the materials and plant for the works.

When the works shall be completed or as soon thereafter as convenient to the SBI a notice in writing will be given to the Contractor/ Vendor to remove his surplus materials and plants and should the Contractor/ Vendor fail to do so within 14 days after receive thereof by him the SBI sell the same by public auction, and after due publication, and shall, adjust the amount

realized by such auction. The Contractor/ Vendor shall have no right to question any of the act of the SBI incidental to the sale of the materials etc.

### 39.0 Certificate of payment

The contractor shall be entitled under the certificates to be issued by the Architect / consultant to the contractor within 10 working days from the date of certificate to payment from SBI from time to time. The SBI shall recover the statutory recovering other dues including the retention amount from the certificate of payment.

Provided always that the issue of any certificate by the Architect / consultant during progress of works or completion shall not have effect as certificate of satisfaction relieve the contractor from his liability under clause.

The Architect / consultant shall have power to withhold the certificate if the work or in part thereof is not carried out to their satisfaction.

The Architect / consultant may by any certificate make any corrections required previous certificate.

The SBI shall modify the certificate of payment as issued by the architect / consultant from time to time while making the payment

The contractor shall not submit interim bills.

The final bill may be submitted by contractor within a period of one month from the date of virtual completion and Architect / consultant shall issue the certificate of payment within a period of two months. The SBI shall pay the amount within a period of three months from the date of issue of certificate provided there is no dispute in respect of rates and quantities.

The contractor shall not submit interim bills.

No advance on materials / plant / machinery or mobilization advance shall be paid in any circumstances.

The SBI shall recover the statutory recoveries viz. TDS, retention and other dues, if any, as per contractual provisions.

The SBI shall have power to withhold the payment if the work or part thereof is not carried out to their satisfaction.

### 40.0 A. Settlement of Disputes and Arbitration

Except where otherwise provided in the contract all questions and disputes to the meaning of the specifications, design, drawings and instructions herein before mentioned and as to the quality of workmanship or materials used on the work or as to any other question , claim, right, matter or thing whatsoever in any way arising out

of or relating to the contract, designs, drawings specifications, estimates, instructions orders or these conditions or otherwise concerning the work or the execution or failure to execute the same whether arising during the progress of the work or after the cancellation, termination, completion or abandonment thereof shall be dealt with as mentioned hereinafter:

- i) If the contractor considers that he is entitled to any extra payment or compensation in respect of the works over and above the amounts admitted as payable by the Architect or in case the contractor wants to dispute the validity of any deductions or recoveries made or proposed to be made from the contract or raise any dispute, the Contractor shall forthwith give notice in writing of his claim, or dispute to the Regional Manager and endorse a copy of the same to the Architect, within 30 days from the date of disallowance thereof or the date of deduction or recovery. The said notice shall give full particulars of the claim, grounds on which it is based and detailed calculations of the amount claimed and the contractor shall not be entitled to raise any claim nor shall the Bank be in any way liable in respect of any claim by the contractor unless notice of such claim shall have been given by the contractor to the Regional Manager in the manner and within the time as aforesaid. The contractor shall be deemed to have waived and extinguished all his rights in respect of any claim not notified to Regional Manager in writing in the manner and within the time aforesaid.

#### B. Settlement of Disputes and Arbitration

The DGM(B&O) shall give his decision in writing on the claims notified by the receipt of the contractor may within 30 days of the receipt of the decision of the DGM (B&O) Submit his claims to the conciliating authority.

- i) If the conciliation proceedings are terminated without settlement of the disputes, the contractor shall, within a period of 30 days of termination thereof shall give a notice to the concerned DGM (B&O) of the SBI for appointment of an arbitrator to adjudicate the notified claims falling which the claims of the contractor shall be deemed to have been considered absolutely barred and waived.
- ii) Except where the decision has become final, binding and conclusive in terms of the contract, all disputes or differences arising out of the notified claims of the contractor as aforesaid and all claims of the SBI shall be referred for adjudication through arbitration by the Sole Arbitrator appointed by the DGM(B&O). It will also be no objection to any such appointment that the Arbitrator so appointed is a SBI Officer and that he had to deal with the matters to which the Contract relates in the course of his duties as SBI. If the arbitrator so appointed is unable or unwilling to act or resigns his appointment or vacates his office due to any reason whatsoever another sole arbitrator shall be appointed in the manner aforesaid by the said DGM (B&O) of the SBI. Such person shall be entitled to proceed with the reference from the stage at which it was let by his predecessor.

It is a term of this contract that the party invoking arbitration shall give a list of disputes with amounts claimed in respect of each dispute along with the notice for appointment of arbitrator.

It is also a term of this contract that no person other than a person appointed by such Chief General Manager as aforesaid should act as arbitrator.

The conciliation and arbitration shall be conducted in accordance with the provisions of the Arbitration & Conciliation Act 1996 or any or any accordance modification or reenactment thereof and the rules made there under.

It is also a term of the contract that if any fees are payable to the Arbitrator these shall be paid equally by both the parties. However, no fees will be payable to the arbitrator if he is a SBI Officer.

It is also a term of the contract that the Arbitrator shall be deemed to have entered on the reference on the date he issues notice to both the parties calling them to submit their statement of claims and counter statement of claims. The venue of the arbitration shall be such place as may be fixed by the arbitrator in his sole discretion. The fees, if any of the arbitrators shall, if required to be paid before the award is made and published, be paid half and half by each of the parties. The Cost of the reference and of the award (including the fees, if any of the arbitrator) shall be in the discretion of the arbitrator who may direct to any by whom and in what manner, such costs or any part thereof, shall be paid and fix or settle the amount of costs to be so paid.

#### 41.0 Method of measurement

Unless otherwise mentioned in the schedule of quantities or in mode of measurement, the measurement will be on the net quantities or work produced in accordance with up to date rules laid down by the Bureau of Indian Standards. In the event any dispute / disagreement the decision of the SBI shall be final and binding on the corrector.

#### 42.0 Maintenance of registers

The contractor shall maintain the following registers as per the enclosed perform at site of work and should produce the same for inspection of STATE BANK OF INDIA /Architect / consultant whenever desired by them. The contractor shall also maintain the records / registers as required by the local authorities / Govt. from time to time.

- i) Register for secured advance
- ii) Register for hindrance to work
- iii) Register for running account bill
- iv) Register for labour

#### 43.0 Force Majeure

43.1 Neither Contractor/ Vendor nor SBI shall be considered in default in performance of the obligations if such performance is prevented or delayed by events such as but not war, hostilities revolution, riots, civil commotion, strikes, lockout, conflagrations, epidemics, accidents, fire, storms, floods, droughts, earthquakes or ordinances or any act of or for any other cause beyond the reasonable control of the party affected or prevents or delayed.

However, a notice is required to be given within 30 days from the happening of the event with complete details, to the other party to the contract.

- 43.2 As soon as the cause of force majeure has been removed the party whose ability perform its obligations has been affected, shall notify the other of such cessation and the actual delay incurred in such affected activity adducing necessary evidence in support thereof.
- 43.3 From the date of occurrence of a case of force majeure obligations of the party affected shall be suspended during the continuance of any inability so caused. With the caused itself and inability resulting there from having been removed, the agreed time completion of the respective obligations under this agreement shall stand extended a period equal to the period of delay occasioned by such events.
- 43.4 Should one or both parties be prevented from fulfilling the contractual obligations by state of force majeure lasting to a period of 6 months or more the two parties, shall mutually decide regarding the future execution of this agreement.

#### 44.0 Local laws, Acts Regulations:

The Contractor/ Vendor shall strictly adhere to all prevailing labour laws including the contract labour (regulation and abolition act of 1970) and other safety regulations. The Contractor/ Vendors should comply with the provision of all labour legislation including the latest requirements of the Acts, laws, any other regulations that are applicable to the execution of the project.

#### 45.0 Accidents

The Contractor/ Vendor shall immediately on occurrence of any accident at or about the site or in connection with the execution of the work report such accident to the architect / consultant. The Contractor/ Vendor shall also such report immediately to the competent authority whenever such report is required to be lodged by the law and take appropriate actions thereof.

46.0 The contractor's shall be bound to comply the following provision in terms of "Restrictions imposed by the Government of India, Ministry of Finance Department of Expenditure under Rule 144 (XI) of General Financial Rules 2017 vide their order no. F. No 6/18/2019/PPD dated 23rd July 2020" as under;

- I. Any bidder from a country which shares a land border with India will be eligible to bid in this tender ONLY if the bidder is registered with the Competent Authority (registration committee constituted by the Department for Promotion of Industry and Internal Trade).
- II. 'Bidder' (including the term 'tenderer', 'consultant' or 'service provider' in certain contexts) means any person or firm or company, including any member of a consortium or joint venture (that is an association of several persons, or firms or companies), every artificial judicial person not falling in any of the descriptions of bidders stated hereinbefore, including any agency branch or office controlled by such person, participating in a procurement process.

- III. 'Bidder from a country which shares a land border with India (such a country)' for this purpose means:
- a. An entity incorporated, established or registered in such a country; or
  - b. A subsidiary of an entity incorporated, established or registered in such a country; or
  - c. An entity substantially controlled through entities incorporated, established or registered in such a country; or
  - d. An entity whose beneficial owner is situated in such a country; or
  - e. An Indian (or other) agent of such an entity; or
  - f. A natural person who is a citizen of such a country; or
  - g. A consortium or joint venture where any member of the consortium or joint venture falls under any of the above
- IV. The beneficial owner for the purpose of (iii) above will be as under:
1. In case of A Company or Limited Liability Partnership, the beneficial owner is the natural person(s), who, whether acting alone or together, or through one or more judicial person, has a controlling interest or who exercises control through other means.  
Explanation-
    - a. "Controlling ownership interest" means ownership of or entitlement to more than twenty-five percent of shares or capital or profits of the company;
    - b. "Control" shall include the right to appoint majority of the directors or to control the management or policy decisions including by virtue of their shareholding or management rights or shareholders agreements or voting agreements;
  2. In case of a partnership firm, the beneficial owner is the natural person(s) who, whether acting alone or together, or through one or more judicial person, has ownership of entitlement to more than fifteen percent of capital or profits of the partnership;
  3. In case of an unincorporated association or body of Individuals, the beneficial owner is the natural person(s), who, whether acting alone or together, or through one or more judicial person, has ownership of or entitlement to more than fifteen percent of the property or the capital or profits of such association or body of individuals;
  4. Where no natural person is identified under (1) or (2) or (3) above, the beneficial owner is the relevant natural person who holds the position of senior managing official;
  5. In case of a trust, the identification of beneficial owner(s) shall include identification of the author of the trust, the trustee, the beneficiaries with fifteen percent or more interest in the trust and any other natural person exercising ultimate effective control over the trust through a chain of control or ownership.
- V. An Agent is a person to do any act for another, or to represent another in dealings with third person.
- VI. The successful bidder shall not be allowed to sub-contract works to any contractor from a country which shares a land border with India unless such contractor is registered with the Competent Authority.
- VII. All bidders need to submit a declaration-cum-certificate (along with evidence) in this regard as per "Annexure Q". Failure to submit such valid declaration-cum-Certificate will make the bid liable for rejection."

## SPECIAL CONDITION OF CONTRACT

### 1. The Technical Bid should contain the following: -

- a. Technical Bid duly signed and sealed on each page.
- b. Banker's Cheque/Demand Draft of Earnest Money deposit.
- c. If any, The Authorization Certificate issued by the Bank's approved Principal Manufacturer only certifying that the tenderer is an Authorized Converter/Agency of their Company and they have been specifically authorized by them (i.e. OEM) to participate in the bidding process of SBI.
- d. If any, An undertaking from the Bank's approved OEM, in original, to the effect that in case their Authorised Agency/Converter is not able to perform contractual obligations for the project during the contract period, the Original Manufacturer shall own full responsibility to comply all contractual obligations relating the captioned work of SBI at their own (i.e. OEM's) risk cost and consequences.

The technical bid not accompanied by above mentioned any one or more documents shall be treated as non-responsive bid and the same shall be summarily disqualified.

### 2. Taxes, duties, levies etc.:

The rates quoted shall be inclusive of all taxes, duties, levies, royalties, fees, cess or charges in respect of the works but excluding GST which shall be payable over and above the approved rates as per actual. Variation of taxes, duties, fees, levies etc. (excluding GST) if any, till completion of work shall be deemed to be included in the quoted rates and no extra claim on this account in any case will be entertained. If a new tax or duty or levy or cess or royalty or octroi is imposed under as statutory law during the currency of contract the same shall be borne by the Contractor/ Vendor. GST will however be paid by the SBI as applicable.

3. The Contractor/ Vendor shall study the schedule of items, technical specifications, drawings, design, etc. for its sufficiency considering all the regulations of local authorities and supply company and code of standard as applicable at the time of submitting the tender and shall bring to the notice of bank, addition or deletion, if any, in writing before due date of submission of tender.

### 4. Acceptance of tender

The SBI shall have the right to reject any or all tenders without assigning any reason. They are not to bind to accept the lowest or any tender and the tenderer or tenderers shall have no right to question the acts of the SBI. However adequate transparency would be maintained by the SBI.

### 5. Dimensions and levels

All dimensions and levels shown on the drawings shall be verified by the contractor and the site and he will be held responsible for the accuracy and maintenance of. All the dimensions and the levels. Figured dimensions are in all cases to be accepted and dimension shall be scaled. Large scale details shall take precedence over small scale drawings. In case of discrepancy the contractor shall ask for clarification from the Architect / consultant before proceeding with the work.

### 6. Notice of operation

The contractor shall not carry out any important operation without the Consent in with from the Architect / consultant:

**7. Construction records**

The contractor shall keep and provide to the Architect / consultant full and accurate records of the dimensions and positions of all new work and any other information necessary to prepare complete drawings recording details of the work as construction.

**8. Safety of adjacent structures and trees**

The contractor shall provide and erect to the approval of the Architect / consultant supports as may be required to protect effectively all structures and protective give to trees, which may be endangered by the execution of the works or otherwise such permanent measures as may be required by the Architect to protect the tree structures.

**9. Temporary works**

Before any temporary works are commenced the contractor shall submit at least in advance to the architect / consultant for approval complete drawings of all temporary works he may require for the execution of the works. The contractor shall carry out the modifications relating to strength, if required by the architect / consultant may require in accordance with the conditions of contract at his own cost the contractor shall be solely responsible for the stability and safety of all temporary works and unfinished works and for the quality of the permanent works resulting from the arrangement eventually adopted for their execution.

**10. Water power and other facilities**

- a) The rate quoted by the contractor shall include all expenses that are required for providing all the water required for the work and the contractor shall make his own arrangements for the supply of good quality water suitable for the construction and good quality drinking water for their workers If necessary the contractor has to sink a tube well / open well and bring water by means of tankers at his own cost for the purpose The STATE BANK OF INDIA will not be liable to pay any charges in connection with the above
- b) The rate quoted in the tender shall include the expenses for obtaining and maintaining power connections and shall pay for the consumption charges
- c) The contractors for other trades directly appointed by the STATE BANK OF INDIA shall be entitled to take power and water connections from the temporary water and power supply obtained by the contractor However, the concerned contractor shall make their own arrangements to draw the supply and pay directly the actual consumption charges at mutually agreed rates between them. All municipal charges for drainage and water connection for Construction purposes shall be borne by the contactor and charges payable for permanent connections, if any, shall be initially paid by the contactor and the SBI will reimburse the amount on production of receipts

- d) The SBI as well as the Architect / consultant shall give all possible assistance to the Contractor's to obtain the requisite Permission from the various authorities, but the responsibility for obtaining the same in time shall be of the contractor

#### 11. Facilities for contractor's employees

The contractor shall make his own arrangement for the housing and welfare of his staff and workmen including adequate drinking water facilities. The contractor shall also make the arrangements at his own cost for transport where necessary for his staff and workmen to and from site of work at his own cost.

#### 12. Lighting of works

The contractor shall at all times provide adequate and approved lighting as required for the proper execution and supervision and inspection of work.

#### 13. Firefighting arrangements

i) The contractor shall provide suitable arrangement for firefighting at his own cost. This purpose he shall provide requisite number of fire extinguishers and adequate number of buckets, some of which are to be always kept filled with sand and some with water this equipment shall be provided at suitable prominent and easily accessible place and shall be properly maintained.

ii) Any deficiency in the fire safety or unsafe conditions shall be corrected by the contractor at his own cost and, to the approval of the relevant authorities. The contractor makes the following arrangements at his own cost but not limited the following:

- a) Proper handling, storage and disposal of combustible materials and waste.
- b) Work operations which can create fire hazards.
- c) Access for fire-fighting equipment.
- d) Type, number and location of containers for the removal of surplus materials and rubbish.
- e) Type, size, number and location of fire extinguishers or other fire fighting equipment.
- f) General house keeping

#### 14. Site order book

A site order book shall be maintained at site for the purpose of quick communication between the Architect / Consultant. Any communication relating to the work may be conveyed through records in the site order book. Such a communication from one party to the other shall be deemed to have been adequately served in terms of contract. Each site order book shall have machine numbered pages in triplicate and shall be carefully maintained and preserved by the contractor and shall be made available to the architect / consultant as and when demanded. Any instruction which the architect / consultant may like to issue to the contractor or the contractor may like to bring to the architect / consultant two copies of such instructions shall

be taken from the site order book and one copy will be handed over to the party against proper acknowledgment and the second copy will be retained for their record.

**15. Temporary fencing/ barricading**

The contractor shall provide and maintain a suitable temporary fencing / barricading and gates at his cost to adequately enclose all boundaries of the site for the protection of the public and for the proper execution and security of the work and in accordance with the requirement of the architect / consultant and regulations of local authorities. These shall be altered, relocated and adopted from time to time as necessary and removed on completion of the work.

**16. Site meetings**

Site meetings will be held to review the progress and quality evaluation. The contractor shall depute a senior representative along with the site representative and other staff of approved sub-contractors and suppliers as required to the site meetings and ensure all follow up actions. Any additional review meetings shall be held if required by the architect/ consultant.

-

**17. Disposal of refuse**

The contractor shall cart away all debris, refuse etc. arising from the work from the site and deposit the same as directed by the architect / consultant at his own cost. It is the responsibility of the contractor to obtain from the local authorities concerned to the effect that all rubbish arising out of contractor's activities at the construction site or any other off-site activities borrow pits has been properly disposed off.

**18. Contractor to verify site measurement**

The contractor shall check and verify all site measurements whenever requested other specialists contractors or other sub-contractors to enable them to prepare the own shop drawing and pass on the information with sufficient promptness as will in any way delay the works.

**19. Displaying the name of the work**

The contractor shall put up a name board of suitable size as directed by the architect/ consultant indicating therein the name of the project and other details as given by the architect/consultant at his own cost and remove the same on completion of work.

**20. As built drawings**

- i) For the drawings issued to the contractor by the Architect / Consultant. The architect Consultant will issue two sets of drawings to the Contractor for the items for some changes have been made. From the approved drawings as instructed by the STATE BANK OF INDIA / Architect / Consultant. The contractor will make the changes made on these copies and return these copies to the architect / Consultant for their approval. In cases revision is required or the corrections are not properly marked the architect / Consultant will point out

the discrepancies to the contractor. The contractor will have to incorporated these corrections and / or attend to discrepancies either on copies as directed by the architect / consultant and resubmit to him for approval. The architect / consultant will return one copy duly approved by him.

ii) For the drawings prepared by the contractor

The contractor will modify the drawing prepared by him wherever the changes made by the STATE BANK OF INDIA / architect / consultant. And submit two copies of such modified drawings to the architect/ consultant for approval. The architect / consultant will return one copy of the approved drawing to the contractor.

**21. Approved make**

The contractor shall provide all materials from the list of approved makes at his own cost and also appoint the specialized agency for the waterproofing anti-termite, aluminum doors and windows and any other item as specified in the tender. The architect/consultant may approve any make / agency within the approved list as given in the tender after inspection of the sample/mock up.

**22. Procurement of materials**

The contractor shall make his own arrangements to procure all the required materials for the work. All wastages and losses in weight shall be to the contractors account

**23. Excise duty, taxes, levies etc.;**

The contractor shall pay and be responsible for payment of all taxes, duties, levies, royalties, fees, cess or charges in respect of the works including but not limited to sales tax, tax on works contract excise duty, and octroi, payable in respect of materials, equipment plant and other things required for the contract. All of the aforesaid taxes, duties, levies, fees and charges shall be to the contractor's account and the STATE BANK OF INDIA shall not be required to pay any additional or extra amount on this account. Variation of taxes, duties, fees, levies etc. if any, till completion of work shall be deemed to be included in the quoted rates and no extra amount on this account. Variation of taxes, duties, fees, levies etc. if any, till completion of work shall be deemed to be included in the quoted rates and no extra claim on this account will in any case be entertained. If a new tax or duty or levy or cess or royalty or octroi is imposed under as statutory law during the currency of contract the same shall be borne by the contractor.

**24. Photographs:**

- The Contractor shall at his own expense supply to the Architects with duplicate hard copies of large photographs not less than 25 cm. x 20 cm. (10" x 8") of the works, taken from two approved portions of each building/premises/branch, at intervals of not more than 2 days during the progress of the work or at every important stage of construction and in case of all hidden items.
- In addition to above, the contractor shall be bound to submit adequate no. of site photographs along with each Running Bill for the project clearing showing major progress of work measured and claimed therein failing which the Architect/ STATE BANK OF INDIA may consider returning the Bill to the contractor and no claim for delay on this account will be entertained.

## SPECIAL CONDITIONS OF CONTRACT FOR ELECTRICAL WORK

### 1. SCOPE OF WORK: -

The scope of work to be carried out under this contract comprises of the supply, installation, testing and commissioning of Electrical work complete as listed out in Schedule of Quantities. The general character and scope of work to be carried out under this contract is presented in drawings and specifications. The contractor shall carry out and complete the said work under this contract in every respect in conformity with the contract documents and with direction of and to the satisfaction of the bank engineer/ Consultant/ Consultant. The contractor shall furnish labour, materials, equipment, transportation and incidentals necessary for the completion of work as described in the Tender Documents.

### 2. FEES AND PERMITS: -

The Contractor shall obtain all permits/licenses and pay for any and all fees required for the installation, inspection and the commissioning of the work.

### 3. DRAWINGS: -

The Drawings prepared by the consultants are indicative only of the general arrangement of the installation work. The Contractor shall follow these drawings and specifications & preparing his shop drawings and subsequent installation. He shall check the drawings of other trades to verify space for his installation.

1. Shop drawings shall be provided of the Main and Sub-Main Switchboards, Distribution Boards, Cable Trays, Reactive Power Compensation Panel, and any other switchboards and panels, wherever applicable and approval shall be obtained from the Consultant / Developer before commencing fabrication or procurement.

2. Any equipment or switchboard manufactured without the written consent of the Consultant / Developer prior to the approval drawings shall be liable for rejection.

Drawings show general run of cables, approximate locations of outlets and equipment, utility symbols and schematic diagrams of no dimensional significance. Refer to the Consultant drawings for locations and also obtain approval from the Consultant / Developer wherever dimensions are not shown, or locations cannot be determined from the drawings. Do not scale drawings to obtain locations

### 4. MEASUREMENTS OF WORK:-

Payment for Conduiting, cables, earth strips and wires etc. will be made on linear measurements and will be measured upto and including the bends.

### 5. TESTING:-

On completion of the installation the testing will be done in conformity with the stipulated performance specifications. Any shortcoming detected in the system/materials/ workmanship shall be rectified by the contractor to the entire satisfaction of the consultant without any extra cost to the owner. The installation shall be tested again after removal of the defects and shall be commissioned only after approval by the competent inspecting authority and the Consultant/Owner.

1. The Contractor shall notify the Consultant at least 7 working days before testing of each system. The Consultant reserves the right to be present when such tests are being made.

2. If the Electrical Inspectorate requires manufacturer's test reports for any equipment used in the project, the Contractor shall obtain such approvals at no extra cost to the client. Such approved reports shall be handed over to the Consultant / client.

Calibration certificates shall be obtained from the Meter and Relay Testing Department of the Electricity Board for all relays and meters used in the project at no extra cost to the client

### 6. COMPLETION CERTIFICATE: -

On completion of the installation a certificate in an approved form shall be furnished by the contractor. The contractor shall be responsible for getting the entire installation duly approved by the Electrical Inspector or other concerned authorities, if any, and shall bear all expenses in connection with the same.

### 7. SCOPE OF WORK

The scope of work to be carried out under this contract briefly comprises of:

a. INTERNAL ELECTRICAL WORK: Supply, Installation, connecting, testing and commissioning of the following:

b. i) Conduiting and wiring for all light points, exhaust fans, Light & power socket outlets, three phase outlets and equipment wiring.

ii) Complete earthing system

iii) Conduiting for Telephone system.

iv) Conduiting for Computer system.

v) All Cables, Mains & Sub-Mains

vi) All Final Distribution Boards.

- All Light fixtures.

- Fire detection system

b) The contractor shall carry out and complete the work under this contract in every respect in confirming with the current rules and regulations of the local Electricity Authority, stipulations of the Indian Standard Institution, and with the directions of and to the satisfaction of the owner. The contractor shall furnish all labour, material, appliances, equipment, transportation and incidentals necessary for providing, installing, testing and commissioning of the whole electrical installation as specified herein and shown as drawings.

This also includes any materials, appliances, equipment and incidental work not specifically mentioned herein or noted on the drawings/documents as being furnished or installed but which are customary to make the installation in working order. The work shall include all incidentals and jobs connected with Electrical installation such as earthing work and cutting chases/holes and making good the same and grouting and equipment.

All Civil works in connection with the Electrical Installation including supply, laying and fixing of necessary inserts, hooks, brackets and sleeves etc

On completion of the work and before issuing of virtual completion certificate the contractor shall submit to owner "As installed drawings" showing all the details of work done by him.

The contractor shall have a valid contracting license before starting the work and till the completion of work.

**TECHNICAL SPECIFICATION**

**1 SPECIFICATIONS FOR INTERNAL WIRING**

**1.1. SYSTEM OF WIRING:**

The system of wiring shall consist of single/multi core FRLS PVC insulated stranded copper conductor wires in non-metallic FRLS PVC conduits/ metallic M.S. conduits as called for in the BOQ. All conduits shall be on the surface, (supported from the Ceiling), in the False Ceiling and concealed in other areas where RCC slab is provided unless otherwise called for in the drawings. All Down conduits shall be concealed unless otherwise called for.

**1.2. GENERAL**

Prior to laying of conduits, the Contractor shall get approved the conduit layout indicating the route of conduit, number and size of conduits, location of junction/ inspection/pull boxes, size and location of switch boxes, point outlet boxes and other details. These conduit layouts shall be got approved by the Consultant and then only conduit layout should be started. Any modification or suggestions shall be approved by the Consultant before the laying of conduits.

**1.3. MATERIALS:**

M.S. conduits shall conform to Indian Standards IS: 1653 - 1964 -Specification for Rigid Steel conduits for Electrical wiring with the latest amendments.

**M.S. CONDUITS:**

M.S. conduits shall be solid drawn or lap welded conduits. Stove enameled inside and outside with minimum wall thickness of 1.6 mm for conduits up to 25 mm diameter and 2.0 mm wall thickness for conduits 32 mm diameter and above.

FRLS PVC conduits to be used for concealed work for all systems except Fire Alarm & Computer system where M.S. conduits shall be used. FRLS PVC conduits shall conform to Indian Standards IS: 9537(Part-3)-1983 -Specification for conduits for Electrical Installation (Part-I) General Requirements.

**FRLS PVC CONDUITS:**

FRLS PVC conduits shall be rigid, unplasticized, heavy gauge having 1.8 mm wall thickness up to 20 mm diameter and 2.0 mm wall thickness for all sizes above 20 mm diameter. Minimum size of conduit shall be 20 mm dia. Minimum size of conduit for Power point wiring shall be 25 mm dia. The conduits shall be delivered to the site of construction in original bundles and each length of conduit shall bear the label of the manufacturer. The number of insulated copper wires that may be drawn into the conduits of various sizes are given below and the fill shall not exceed 40% the maximum permissible number of 650/1100 volts grade single/multi core PVC insulated copper conductor wires of different sizes, that may be drawn into rigid metallic or non-metallic conduits.

<u>SIZE OF WIRE</u>	<u>SIZE OF CONDUITS (MM)</u>				
	20	25	32	40	50 nominal dia in mm
Nominal cross- Sectional area of wires in sq. mm	( Maximum number of wires )				
1.5	5	6	18	-	-
2.5	3	4	10	-	-
4.0	2	3	5	10	-
6.0	-	4	6	8	-
10.0	-	-	3	4	-
16.0	-	-	-	3	5
25.0	-	-	-	2	3

**1.4 FRLS PVC CONDUIT ACCESSORIES & CONNECTIONS:**

The accessories used for FRLS PVC conduits shall conform to Indian Standards IS: 3419-1988-(Specification for fittings for non-metallic conduits).PVC conduits shall be joined by means of screwed or plain couplers. Where there are long runs of straight conduits, inspection boxes shall be provided at intervals as approved by the consultant. The threads of the pipe and sockets shall be free from grease and oil. It shall be thoroughly cleaned before making the screwed/plain joints. Proper jointing materials as recommended by manufacturers shall be used for jointing of FRLS PVC pipes. Use PVC couplers and connectors for FRLS PVC pipe connections and terminations in boxes. All the joints shall be fully watertight. Junction boxes and running joints shall be provided at suitable places to allow for subsequent extensions if any, without undue dismantling of conduit system. As far as possible diagonal run of conduits shall be avoided. Junction between conduit and adapter boxes, back outlet boxes, switch boxes and the like must be provided with entry spouts and smooth PVC bushes. Joints between conduit and iron clad Distribution Boards or control gear shall be affected by means of conduit couplers into each of which will be coupled smooth PVC bush from the inside of

box or case. Conduit system shall be erect and straight as far as possible. All jointing methods shall be subject to the approval of the consultant.

#### BENDS IN CONDUITS:

Where necessary bends or diversions may be achieved by means of bends and or circular inspection boxes with adequate and suitable inlet and outlet screwed joints. In case of recessed system each junction box shall be provided with a cover properly secured and flush with the finished wall surface, so that the conductors inside the conduits are easily accessible. No bend shall have a radius of less than 2.5 times the outside diameter of the conduit. Conduits shall be cold bend by means of a Bending spring available with the manufacturers. In case it is not available then Heat may be used to soften the PVC conduits, by filling sand in the pipe. Use of PVC conduit in places where ambient temperature is 60 degrees or above is prohibited. PVC Solvent shall be used for joints between conduits, conduits & Junction box etc. PVC checknuts and bushes shall be used for joining conduit with outlet boxes. PVC Closures shall be provided on unused mouths of Junction boxes.

Separate conduits shall be provided for the following system.

- i) Lights, Exhaust fans & 5A Light sockets.
- ii) Power sockets
- iii) Telephone System
- iv) Television, Computer & Music system
- v) Emergency System.
- vi) Public Address System
- vii) Fire Alarm System.

Separate switchboards/outlets shall be provided for the following system.

- i) Lights, Exhaust fans & 5A Light sockets.
- ii) Power sockets & A/C outlets
- iii) Telephone System
- iv) Television, Computer & Music system
- v) Emergency System.
- vi) Public Address System
- vii) Fire Alarm system.

#### 1.5 FIXING CONDUITS:

Conduits and junction boxes shall be kept in position and proper holdfasts shall be provided. Conduits shall be so arranged as to facilitate easy drawing of wires through them. Adequate junction boxes of approved shape and size shall be provided. All conduits shall be installed so as to avoid steam and hot water pipes. After the conduits, junction boxes, outlet boxes & switch boxes are installed in position their outlets shall be properly plugged so that water, mortar, insects or any other foreign matter does not enter into the conduit system. Exposed conduits shall be fixed by means of spacer bar/ saddles at intervals of not more than 600 mm in normal run and 500 mm from both sides of fitting or accessories. The saddles shall be of 3 mm x 19 mm mild steel flat, properly treated with primer and painted, securely fixed to support by means of nuts and bolts/raw bolts and MS screws as required.

Conduits shall be laid in a neat and organised manner as directed and approved by the Consultant. Conduit runs shall be planned so as not to conflict with any other service pipelines/ducts.

Where exposed conduits are suspended from the structure they shall be clamped firmly and rigidly to hangers of design to be approved by the Consultant. Where hangers are to be anchored to reinforced concrete appropriate inserts and necessary devices for their fixing shall be provided at the time of fixing. Making holes or openings in the concrete will generally not be allowed. In case it is unavoidable prior permission of the Consultant shall be obtained. Conduits shall be fixed in the chase by means of staples not more than 600 mm apart and the chase filled with cement mortar 1 : 4 . Cutting of horizontal chases in walls is prohibited.

#### 1.6. PROTECTION

To minimize condensation or sweating inside the conduit pipes all outlets of conduit system shall be adequately ventilated as directed and approved by the Consultant. All screwed and socketed connections shall be adequately made fully watertight by the use of proper jointing materials i.e.Tropolin for PVC conduits & white lead for metal conduits.

#### 1.7. SWITCH-OUTLET BOXES AND JUNCTION BOXES

All boxes shall conform to Indian Standards IS: 5133(Part-1)-1969 (Specification for boxes for enclosure of Electrical accessories) with the latest amendments. All outlet boxes for switches, sockets & other receptacles shall be fabricated from 1.6mm thick mild steel sheets duly painted with rust proof paint (zinc passivated) as called for, having smooth external & internal surfaces to true finish. Junction boxes and outlet boxes in contact with earth or installed in

areas exposed to the weather shall be of 2mm thick mild steel and painted. Where called for, outlet boxes for receiving switches, telephone outlets T.V. outlets, power plugs etc. shall be fabricated to prove shape and size to suit the cover plates of approved make for different utilities. The cover plates shall be of best quality Hylam sheets or ISI grade Urea Formaldehyde Thermosetting insulating material which shall be both mechanically strong and fire retardant, as approved by the Consultant. Proper supports shall be provided in the outlet boxes to fix the cover plates of switches as required. Separate screwed earth terminal shall be provided inside the box for earthing purpose. All boxes shall have adequate number of knockout holes of required diameter for conduit entry. Where called for outlet boxes for receiving switches and fan regulators in one box, shall be fabricated to approved shape and size to accommodate fan regulators and switches to be fixed on grid plates. These boxes shall be covered with Hylam sheets or ISI grade Urea Formaldehyde Thermosetting insulating material which shall be both mechanically strong and fire retardant. All junction boxes pull boxes and outlet boxes shall be provided with sheet cover Urea Formaldehyde Thermosetting insulating material. The box cover shall be secured to the box with adequate number of round head brass screws of approved make. Outlets exposed to the weather shall be fully weather tight, complete with rubber gasketed covers, glass where used shall be fully heat resistant for the duty. The outlet boxes shall be painted with two coats of bitumastic paint before they are fixed in position. All Outlet boxes fixed in concrete/recessed in wall shall be of a minimum depth of 55mm.

#### 1.8. INSPECTION BOXES

Rust proof (Zinc passivated) inspection boxes of 1.6mm thick mild steel sheet and of required size, having smooth external and internal finish shall be provided to permit periodical inspection and to facilitate removal and replacement of wires when required. Inspection boxes shall be mounted flush with ceiling/walls finished surface and shall be provided with screwed covers of Urea Formaldehyde Thermosetting insulating material sheet cover secured to the box with brass screws. Adequate holes shall be provided for ventilation in the inspection box covers.

#### 1.9. CONDUCTORS

FRLS PVC insulated multistrand copper conductor wires of 1100 Volts grade shall be used for three phase distribution and FRLS PVC insulated multistrand copper conductor wires of 1100 V grade shall also be used for Single phase distribution and shall conform to IS : 694 -1964 with the latest amendments and shall be ISI marked.

#### 1.10. BUNCHING OF WIRES

Wires carrying current shall be so bunched in the conduit that the outgoing and return wires are drawn into the same conduit. Wires originating from two different phases shall not be run in the same conduit.

#### 1.11. DRAWING OF CONDUCTORS

The drawing and jointing of copper conductor wires shall be executed with due regard to the following precautions, while drawing insulated wires into the conduits. Care shall be taken to avoid scratches and kinks which cause breakage of conductors. There shall be no sharp bends.

Insulation shall be shaved off for a length of 15mm at the end of wire like sharpening of a pencil and it shall not be removed by cutting it square or ringing.

FRLS PVC insulated copper conductor wire ends before connection shall be properly soldered (at least 15mm length) with special Cu solder for copper conductor or shall be properly crimped with copper lugs/sockets as the case may be. Strands of wires shall not be out for connecting to the terminals. All strands of wires shall be soldered at the end before connection. The connecting brass-screws shall have flat ends. All looped joints shall be soldered and connected through terminal block/connectors. The pressure applied to tighten terminal screws shall be just adequate, neither too much nor too less. Conductors having nominal cross-sectional area exceeding 6 Sq mm shall always be provided with cable sockets.

At all bolted terminals, brass flat washer of large area and approved steel spring washers shall be used. Brass nuts and bolts shall be used for all connections.

Only certified wiremen and cable jointers shall be employed to do jointing work. All wire shall bear the manufacturer's label and the voltage grade at one-meter intervals for the full length of coil and shall be brought to site in new and original packages.

The sub-circuit wiring for points shall be carried out in looping system and no joint shall be allowed in the length of the conductors. No wire shall be drawn into any conduit, until all work of any nature, that may cause injury to wire is completed. Care shall be taken in pulling the wires so that no damage occurs to the insulation of the wire. Before the wires are drawn into the conduits the conduits shall be thoroughly cleared of moisture, dust, and dirt or any other obstruction by Drawing dry cloth through the conduits. The minimum size of FRLS PVC insulated stranded copper conductor wire for all sub circuit wiring for lights, exhaust fans, ceiling fan and 5A Light sockets points shall be 1.5 Sq mm. In case of power circuit not more than two 15 Amp power outlets shall be grouped in one circuit, wiring for the first power outlet shall be carried out with FRLS PVC insulated 6.0 sq mm copper conductor wires. Wiring for the second power outlet shall be carried with FRLS PVC insulated 4.0 sq mm copper conductor wires. All power outlets shall be connected with 4.0 sq mm FRLS PVC insulated copper conductor wires to the earth terminal of outlet. Separate circuit

shall run with FRLS PVC insulated 4.0 sq mm copper conductor wires for water heaters, kitchen equipment, window Air conditioners and similar outlets at locations as shown on drawings.

The minimum size of wire from final distribution board to first tapping point in the circuit shall be 2.5 Sq mm FRLS PVC insulated stranded copper conductor wires. Circuit shall not have more than a total of 8 points of fans, 5A Light sockets and Light points and its load shall not exceed 800 watts. Not more than two power circuits shall be drawn through the same conduit. Separate earth wire shall run for each circuit. In case two circuits of the same phase are running in the same conduit then a common earth wire is permissible. The size of earth wire for all the light points, ceiling fans, exhaust fans, light sockets, outlet boxes etc. shall be 1.5 sq mm FRLS PVC insulated copper conductor wires.

#### 1.12. JOINTS

All joints shall be made at main switches, distribution boards, socket outlets, lighting outlets and switch boxes only. No joints shall be made inside conduits and junction boxes. Conductors shall be continuous from outlet to outlet. Joints where unavoidable, due to any specified reasons, prior permission in writing shall be obtained from the Consultant before making such connections.

#### 1.13. MAINS AND SUB-MAINS

Mains and sub-mains wires where called for shall be of the rated capacity and approved make. Every main and sub-main shall be drawn into an independent adequate size conduit. Adequate size draw boxes shall be provided at convenient locations to facilitate easy drawing of the mains and sub-mains. An independent earth wire of proper rating shall be provided. The earth wires shall run along the entire length of the mains and sub-mains. The earth wires shall be fixed to conduits by means of suitable copper clips at not more than 1000mm distance. Where mains and sub-main cables are connected to switch gears, sufficient extra length of sub-main and main cable shall be provided to facilitate easy connections and maintenance.

#### 1.14. LOAD BALANCING

Balancing of circuits in three phase installation shall be planned before the commencement of wiring, shall be got approved by the Consultant and shall be strictly adhered to.

#### 1.15. COLOUR CODE OF CONDUCTORS

Colour code shall be maintained for the entire wiring installation; red, yellow, blue for three phases and "off" circuit black for neutral and green for earth (or bare earth wire)

Telephone Multicore cables shall be of approved make and shall conform to following specifications.

- i) Type of conductor .... Electrolytic Annealed Tinned Cu conductor. (ATC)
- ii) Diameter of Conductor ... 0.61 mm dia uniform (minimum size)
- iii) Weight of conductor .... 2.52 Kg/Km minimum. iv) Resistance of conductor at 20 degree... 60 Ohms/Km,
- v) Radial Thickness of PVC insulation... 0.3mm  $\pm$  0.05mm uniform
- vi) Radius Thickness of PVC sheathing ... 1.2mm uniform  $\pm$  0.2mm
- vii) Overall diameter of insulated conductor. 1.2mm uniform
- viii) High voltage Test. Able to withstand upto 500 volts D.C. up to 12 hours immersion in water.

#### 1.16 M.S. CONDUIT ACCESSORIES & CONNECTIONS:

The accessories used for M.S. conduits shall conform to Indian Standards IS: 3837-1966-(Specification for fittings for Rigid steel conduits with the latest amendments. M.S. conduits shall be joined by means of screwed or plain couplers. Where there are long runs of straight conduits, inspection boxes shall be provided at intervals as approved by the Consultant. The threads of the pipe and sockets shall be free from grease and oil. It shall be thoroughly cleaned before making the screwed/plain joints.

Proper jointing and Cleaning materials as recommended by manufacturers shall be used for jointing and cleaning of M.S. pipes. Use M.S. couplers and connectors for M.S. pipe connections and terminations in boxes. All the joints shall be fully watertight. Junction boxes and running joints shall be provided at suitable places to allow for subsequent extensions if any, without undue dismantling of conduit system. As far as possible diagonal run of conduits shall be avoided. Junction between conduit and adapter boxes, back outlet boxes, switch boxes and the like must be provided with entry spouts and smooth M.S. bushes and M.S. Checkouts. Joints between conduit and iron clad Distribution Boards or control gear shall be affected by means of conduit couplers into each of which will be coupled smooth M.S. bush from the inside of box or case. Conduit system shall be erect and straight as far as possible. All jointing methods shall be subject to the approval of the Consultant.

#### M.S. CONDUIT CONNECTIONS:

Conduit connections for MS conduits shall be screwed metal to metal and be painted with one coat of self-etching zinc chromate primer and two coats of enamel paint. The threads and sockets shall be free from grease and oil. Connections between screwed conduit and sheet metal boxes shall be by means of a brass hexagon smooth bore bush,

fixed inside the box. Checkouts to be provided on inside and outside of box and connected through a coupler to the conduit or as directed by the Consultant. The joints in the conduits shall be free of burrs to avoid damage to insulation of conductors while pulling them through the conduits. Connections between PVC and MS conduits shall be through a junction box. Direct connection between PVC and MS conduits is not allowed.

## 2 CABLES

### - GENERAL

MV Cables shall be supplied, laid tested and commissioned in accordance with drawing specifications, relevant Indian Standards specification, Indian Electricity Act and manufacturer's instructions. The cable shall be delivered at site in original drums with manufacturers name clearly written on the drums.

### - MATERIAL

MV CABLES : MV Cables shall be FR XLPE PVC insulated aluminium conductor armoured and unarmoured cables conforming to IS: 1554 (part I&II)-1976 & IS : 694-1977 (PVC Insulated cables for working voltages up to and including 1100 volts (second revision) with latest amendments. MV cables shall be suitable for underground use and laid in trenches, ducts, cable trays, under roads and paved areas. MV Cables shall be termite resistant and shall be of approved make.

### - JOINTS IN CABLES

The contractor shall take care to see that all the cables are apportioned to various locations in such a manner as to ensure no straight joints in the cable run. If the straight joint in cable is unavoidable due to any specified reasons, prior permission in writing shall be obtained from the Consultant before the use of such straight joints in cable.

### - JOINTING BOXES FOR CABLES

Cable jointing boxes shall be of appropriate size, suitable for PVC insulated cables of particular voltage ratings, and shall be manufactured by approved manufacturers.

### - JOINTING OF CABLES

All cable joints shall be made in suitable approved cable joint boxes. Jointing of cables in the joint boxes and the filling in of compound shall be done in accordance with the best practice in trade, in accordance with manufacturer's instructions and in an approved manner. All straight Joints shall be done in epoxy mould boxes with TROPOLIC/ M-Seal resin or approved equal. All terminal ends of conductors shall be heavily soldered upto at least 50mm length.

All cables shall be jointed colour to colour and tested for insulation resistance and continuity before jointing commences. The seals of cables must not be removed until preparations for jointing are completed. Joints shall be finished on the same day as commenced and sufficient protection from the weather shall be arranged.

### - FILLING OF EPOXY COMPOUND

Equal quantities of resin and hardner shall be taken and mixed thoroughly by hand until the mixture is free from white patches and has uniform colour. No water, oil or any other liquid shall be added to the mixture to make it soft as this will affect the properties of the compound. The mixture shall be used within 30-40 minutes of mixing. The surface on which epoxy compound is to be used shall be free from dust, rust, oil, grease and shall be dry. No disturbance or movement of joint shall be made till the epoxy compound has completely hardened. A smooth surface can be made by rubbing a damp cloth smoothly on the compound before it sets. The joints shall be painted after it has completely hardened.

### - CABLES TERMINATION

Cable termination shall be done in terminal cable box using cable glands and the cable ends sealed with sealing compound.

### - BONDING OF CABLES

Where a cable enters any piece of apparatus, it shall be connected to the casing by means of an approved type of armoured clamps and gland. The clamps must grip the armouring firmly to the gland or casing, so that in the event of ground movement no undue stress is passed on to the cable conductors. The glands shall be either to the lead sheath by means of 'Plumbing Joint' as on a cone of approved materials, capable of being compressed into lead sheath. The gland or cone shall be capable of effecting a good electrical bond between both the armouring and lead of the cable and the casing.

## 2.9. LAYING OF CABLES

Cables shall be laid by skilled and experienced workmen using adequate rollers to minimize stretching of the cable. The cable drums shall be placed on jacks before unwinding the cable. Great care shall be exercised in laying cable to avoid forming kinks. The drums shall be unrolled, and cables run over wooden rollers in trenches at intervals not exceeding 2 meters. Cables shall be laid at depth of 750mm depth below ground level in the case of MV Cables. A cushion of sand, not less than 75mm shall be provided both above and below the cable, joint boxes and other accessories. HV and MV cables shall not be laid in the same trench and/or alongside of water main. The cable shall be laid in excavated trench 80mm layer of sand shall be spread over the cable. The cable then shall be lifted and placed

over the sand bed. The second layer of 80mm sand then be spread over the cable. The relative position of the cables laid in the same trench shall be preserved and the cables shall not cross each other as far as possible. At all changes in direction in horizontal and vertical planes, the cable shall be bent smooth with a radius of bend not less than 12 times the diameter of cable. Minimum 3 M long loop shall be provided at both sides of every straight joint and 5 Meters at each end of the cable. Distinguishing marks shall be made on the cable ends for identification. Insulation tapes of appropriate voltage and in red, yellow and blue colours shall be wrapped just below the sockets for phase identification. Aluminium Labels etched with the size of cable shall be provided around the two ends of each cable.

#### 2.10. PROTECTION OF CABLES

The cable shall be protected by placing burnt bricks over the cables 600mm wide on the top layer of sand for the full length of underground cable. Where more than one cable is running in the same trench, the bricks shall cover all the cables and shall project a minimum of 80mm on either side of the cable.

Cable under road crossings and any surfaces subjected to heavy traffic, shall be protected by running them through Hume pipes of suitable size and Heavy grade quality.

Cables under paved areas (which form part of the building) shall be protected by running them through Stoneware/Hume pipes of 150 mm dia(minimum size) one meter below road level.

#### 2.11. CABLES INSIDE BUILDINGS

Cables inside buildings shall be laid either in masonry trenches or carried on through trays or brackets. Where cables run in ducts inside the buildings the cables shall be adequately clamped to angle iron brackets, secured to the wall, as directed and approved by the Consultant. Where cables are suspended from ceilings, they shall be carried over troughs or trays as directed and approved by the Consultant. The supports shall be placed not more than 1.0 meter apart. All cables passing through walls below paved area, and concrete shall run through stone ware pipes or Hume pipes of adequate diameter recessed or exposed as directed. Cables running along walls shall be supported and clamped to saddles, or hanger rigidly anchored at close intervals. Clear space between parallel cables shall be equal to the diameter of the cable but not less than 50mm. Where called for cable trenches shall be filled with fine sand. The contractor shall ensure that hangers, brackets and other supporting arrangements for cables are placed in proper position at the time of building the walls, concreting slabs, etc. cutting holes or opening in concrete may be carried out only with prior permission of the Consultant.

All excavations and back fill including timbering, shoring and pumping required for the installation of the cables shall be carried out as per the drawings and requirements laid down elsewhere. Trenches shall be dug true to line and grades. Back fill for trenches shall be filled in layers not exceeding 150mm. Each layer shall be properly rammed and consolidated before laying the next layer. The Contractor shall restore all surfaces roadways, sidewalks, curbs, walls or other works cut by excavation of their original condition, to the satisfaction of Consultant.

#### 2.12. MARKERS AND WARNING PLATES

Approved CI cables markers shall be provided along the route of the cables at every 30-meter distance and at both ends of road crossing, indicating HV cables and MV cables as applicable. Special CI markers shall be provided at all buried cable joints indicating "Electrical Cable Joints. GI plates engraving the size of cable and the place it serves shall be tied to the cable at regular intervals of 2 meters for easily identification of the cables.

#### 2.13. TESTING OF CABLES

Prior to burying of the cables, following tests shall be carried out:

- a. Insulation test between phases and phase to earth for each length of cable before and after jointing.

On completion of cable laying work and jointing the following tests shall be conducted in the presence of the Consultants.

- a. Insulation Resistance test (Sectional and Overall)
- b. Continuity Resistance Test.
- c. Sheath continuity Test.
- d. Earth Test.
- e. Physical Dimensions Test.

All tests shall be carried out in accordance with relevant Indian Standard Codes of practice and Indian Electricity Rules. The contractor shall provide necessary instruments, equipment and labour for conducting the above test and shall bear all expenses in connection with such tests. All tests shall be carried out in the presence of the Consultant / Consultant.

### 3.0 EARTHING

#### 3.1 EARTHING

All the non-current metal parts of electrical installation shall be earthed properly. All metal conduits, trunking, cable sheaths, switchgear, outlet boxes, distribution boards, light fittings, fans and all other parts made of metal or conductive material shall be bonded together and connected by means of specified earthing system. All earthing will be in

conformity with the relevant provision of Rules 33 and 61 of the Indian Electricity Rules 1956 and Indian Standard Specifications IS:3043-1987 with latest amendments.

### 3.2. EARTHING CONDUCTORS

All earthing conductors shall be of high conductivity electrolytic copper of 99 % purity and shall be protected against mechanical injury or corrosion.

### 3.3. SIZING OF EARTHING CONDUCTORS

The cross-sectional area of copper earthing conductor shall be same as the active conductor for sizes of active copper conductor upto 4.0 sqmm and shall be half the size for 16 sq mm active copper conductor and above. All fixtures, fans, outlet boxes and junction boxes shall be earthed with 1.5 sqmm PVC Insulated copper conductor wires. All power sockets and single-phase A/C units shall be earthed with 4.0 PVC Insulated copper conductor wires. All Three phase Final Distribution Boards shall be earthed with 2 nos 4 mm dia bare copper conductor wires. The sizes of the earth continuity conductors should not be less than half of the largest current carrying conductors.

The Sub-Distribution Board shall be earthed to 2 nos 600mm x 600mm x 3mm copper plate earthing stations through 25m x 3 mm copper strips.

### 3.4. CONNECTION OF EARTHING CONDUCTORS

Main earthing conductors shall be taken from the earth connections at the main switchboards to an earth electrode with which the connection is to be made. Submain earthing conductors shall run from the main switchboard to the sub-distribution boards. Final distribution boards earthing conductors shall run from sub-distribution boards.

### 3.5. PROHIBITED CONNECTIONS

Neutral conductor, sprinkler pipes, or pipes conveying gas, water, or inflammable liquid, structural steel work, metallic enclosures or cables and conductors, metallic conduits and lightning protection system conductors shall not be used as a means of earthing an installation or even as a link in an earthing system. The electrical resistance of metallic enclosures for cables and conductors measured between earth connections at the main switchboard and any other point on the completed installation shall be low enough to permit the passage of current necessary to operate fuse or circuit breakers and shall not exceed 1 ohm.

### 3.6. PROTECTION FROM CORROSION

Connections between copper and galvanised equipment shall be made on vertical face and protected with paint and grease. Galvanised fixing clamps shall not be used for fixing earth conductors. Only copper fixing clamps shall be used for fixing earth conductors. When there is evidence that the soil is aggressive to copper, buried earthing conductors shall be protected by suitable serving and sheathing.

### 3.7. EARTHING STATION

**Plate Electrode Earthing:** Earthing electrode shall consist of a tinned copper plate not less than 300mm x 300mm x 3mm thick as called for in the Schedule. The plate electrode shall be buried as far as practicable below permanent moisture level but in any case, not less than 4.2 meters below ground level. Wherever possible earth electrodes shall be located as near the water tap, water drain or a down take pipe as possible. Earth electrodes shall not be installed in proximity to a metal fence. It shall be kept clear of the buildings foundations and in no case shall it be nearer than 2 meters from the outer face of the wall. The earth plate shall be set vertically and surrounded with 150mm thick layer of charcoal, dust and salt mixture. 20mm GI pipe shall run from the top edge of the plate to the ground level. The top of the pipe shall be provided with a funnel and a mesh for watering the earth through a pipe. The funnel over the GI Pipe shall be housed in a masonry chamber, approximately 300mm x 300mm x 300mm deep. The masonry chamber shall be provided with a cast iron cover resting over a GI frame embedded in masonry. Refer Sketch for additional details.

**Pipe Electrode Earthing:** Earthing electrode shall consist of a GI Pipe (class 'A') Indian Tube Company make or approved equal not less than 40mm dia and 4.5 meters long. GI Pipe electrode shall be cut tapered at the bottom and provided with holes of 12mm dia drilled at 75mm interval upto 2.5 meters length from bottom. The electrode shall be buried vertically in the ground as far as practicable below permanent moisture level with its top not less than 1.25 M below ground level. The electrode shall be in one piece and no joints shall be allowed in the electrode. Wherever possible earth electrodes shall be located as near water tap, water drain or a down take pipe. Earth electrodes shall not be located in proximity to a metal fence. It shall be kept clear of the building foundations and in no case shall be nearer than 2 meters from the outer face of the wall. Refer Sketch for additional details.

The pipe earth electrode shall be kept vertically and surrounded with 150mm thick layer of charcoal dust and salt mixture upto a height of 2.5 meters from the bottom. At the top of the electrode a funnel with a mesh shall be provided for watering the earth. The main earth conductors shall be connected to the electrode just below the funnel, with proper terminal lugs and check nuts. The funnel over the GI pipe and earth connection housed in a masonry chamber, approximately 350mm deep. The masonry chamber shall be provided with a cast iron cover resting over a CI frame embedded in masonry.

### 3.8. EARTH CONNECTION

All metal clad switches and other equipment carrying single phase current, shall be connected to earth by a single connection. All metal clad switches carrying medium voltage and high voltage shall be connected with earth by two separate and distinct connections. The earthing conductors inside the building wherever exposed shall be properly protected from mechanical injury by running the same in GI Pipe of adequate size.

Earthing conductors outside the building shall be laid 600mm below the finished ground level. The over lapping in copper strips at joints where required, shall be minimum 75mm. The joints shall be riveted and brazed with copper rivets and greased in approved manner. Sweated lugs of adequate capacity and size shall be used for all termination of wires above 1 Sqmm size and bare copper wire above 2.0mm dia. Lugs shall be bolted to the equipment body after the metal body is cleaned of paint and other oily substance and properly tinned. The earth wires entering the Final Distribution Boards shall be terminated with copper sockets crimped to its ends and tightened to the terminal with the help of flat end brass screws.

### 3.9. EARTH RESISTANCE

The earth resistivity of the soil where the earthing stations are located shall be submitted to the Consultant before the earthing work starts and get the approval of the Consultant/Owner. If the earth resistance is too high and multiple electrode earthing does/not give adequate low resistance to earth, than the soil resistivity immediately surrounding the earth electrodes shall be reduced by adding sodium chloride, calcium chloride, sodium carbonate, copper sulphate, salt and soft coke or charcoal in suitable proportions as directed by the consultants.

### 3.10. RESISTANCE TO EARTH

The resistance of each earth system shall not exceed 1.0 ohm in the case of Medium Voltage system and 0.5 ohm in the case of High Voltage system.

## 4 TESTING

### GENERAL

On completion of the work the entire installation shall be subject to following tests:

- a) Wiring Continuity Test
- b) Insulation Resistance Test
- c) Earth Continuity Test
- d) Earth Resistively Test

Besides the above any other test specified by the local Authority shall also be carried out.

All tested and calibrated instruments for testing, labour, materials and incidentals necessary to conduct the above tests shall be provided by the Contractor at his own cost.

### TESTING OF WIRING

All wiring systems shall be tested for continuity of circuits, short circuits and earthing after wiring is complete and before energising. The Test Certificates for the complete wiring shall be submitted in the Format and the Total Electrical Installation shall be got approved by the Electrical Inspector.

### INSULATION RESISTANCE TEST

The insulation resistance shall be measured by applying between earth and the whole system of conductors, or any section thereof with all fuses in place and all switches closed (except in concentric wiring) all lamps in position of both poles of the installation, otherwise electrically connected together, a direct current pressure of not less than twice the working pressure (provided that it does not exceed 660 volts for medium voltage circuits) be applied. Where the supply is derived from A.C. three phase system, the neutral pole of which is connected to earth, either direct or through added resistance, pressure shall be deemed to be that which is maintained between the phase conductor and the neutral. The insulation resistance measured as above shall not be less than 50 divided by the number of points on the circuit provided that the whole installation shall not be required to have an insulation resistance greater than one mega ohm. The insulation resistance shall not be measured between all conductors connected to one phase conductor of the supply and all the conductors connected to the middle wire or to the neutral or to the other phase conductors of the supply. Such a test shall be carried out after removing all metallic connections between the two poles of the installation and in these circumstances the insulation resistance between conductors of installation shall not be less than that specified above.

The insulation resistance between the case of frame work of housing and power appliances, and all live parts of each appliance shall not be less than that specified in the relevant Indian Standard Specifications or where there is no such specification shall not be less than half a mega ohm.

### TESTING OF POLARITY OF NON-LINKED SINGLE POLE SWITCHES

In a two wire installation a test shall be made to verify that all non-linked single pole switches have been fitted in the same conductor throughout, and such conductor shall be labeled or marked for connection to an outer or phase conductor or to the non-earthed conductor of the supply. In the three or four wire installation a test shall be made to verify that every non-linked single Pole switch is fitted in a conductor to one of the outer or phase conductor of the

supply. The entire electrical installation shall be subject to the final acceptance of the Consultant as well as the local authorities.

#### 4.5. EARTH RESISTIVITY TEST

Earth resistivity test shall be carried out in accordance with Indian Standard code of practice for earthing IS: 3043:1987. All tests shall be carried out in the presence of the Consultant/Owner.

#### 4.6 TEST CERTIFICATES

The Electrical Installation shall be tested as per relevant Indian Standards and Test Certificate to this effect shall be submitted to the Owner. The Contractor has to get the Total Electrical Installation approved by the Electrical Inspector and the permission to energise the same shall be submitted to the Owner.

### 5 SAFETY REQUIREMENTS

#### 5.1 SCOPE

This section covers the requirements of items to be provided in the sub-station for compliance with statutory regulations, safety and operational needs.

#### 5.2 REQUIREMENTS

Safety provisions shall be generally in conformity with the relevant Indian Standards and I.E. Rules and Regulations. In particular the following items shall be provided.

##### (a) Insulation Mats

Insulation Mats conforming to IS: 5424-1969 shall be provided in front of main switch boards and other control equipment as specified.

##### (b) First Aid Charts and First Aid Box

Charts (one in English, one in Hindi, one in Regional language), displaying methods of giving artificial respiration to a recipient of electrical shock shall be prominently provided at appropriate place. Standard First Aid Boxes containing materials as prescribed by St. John Ambulance brigade or Indian Red Cross should be provided in each sub-station.

##### (c) Danger Plate

Danger plates shall be provided on HV and MV equipments. MV danger notice plate shall be 200mm x 150mm made of mild steel at least 2mm thick vitreous enameled white on both sides and with inscriptions in signal red colour on front side as required.

##### (d) Fire Extinguishers

Portable CO<sub>2</sub> conforming to IS: 2878-1976 dry chemical conforming to IS 2171-1976 extinguishers shall be installed in the sub-station at suitable places as specified.

##### (e) Fire Buckets

Fire buckets conforming to IS: 2546-1974 shall be installed with the suitable stand for storage of water and sand.

##### (f) Toolbox

A standard toolbox containing necessary tools required for operation and maintenance shall be provided in sub-station.

##### (g) Caution Board

Necessary number of caution boards as "Man online" "Don't switch on' etc. shall be available in the sub-station.

##### (h) Keyboard

A key board of required size shall be provided at a proper place containing castel key, and all other keys of sub-station and allied areas.

#### 6.0 M V PANELS, SUB-DISTRIBUTION BOARDS & FINAL DISTRIBUTION BOARDS

6.0 The PANELSs shall be suitable for operation on 3 phase, 4 wire, 415 Volts, 50 cycles, neutral grounded at transformer and short circuit level not less than 31 MVA at 415 volts.

The PANELS shall comply with the latest edition of relevant Indian Standards and Indian Electricity Rules and Regulations. All PANELSs shall be fabricated by the contractor by using specified components as per the specifications given below:

#### 6.1 CONSTRUCTION FEATURES

The PANELSs shall be metal enclosed sheet steel cubical, indoor, dead front, floor mounting type. The distribution boards shall be totally enclosed, completely dust and vermin proof. Gaskets between all adjacent units and beneath all covers shall be provided to render the joints dust proof. PANELSs shall be preferably arranged in multitier formation. All doors and covers shall be fully gasketed with foam rubber and/or rubber strips and shall be lockable. All MS sheet steel used in the construction of PANELSs shall be 2mm thick and shall be cut to different sizes and bolted as necessary to provide a rigid support for all components. Joints of any kind in sheet metal shall be bolted type and not

welded type.

All covers shall be properly fitted and square with the frame, and holes in the PANELS correctly positioned. Fixing screws shall enter into holes tapped into an adequate thickness of metal or provided with hank nuts. Self-threading screws shall not be used in the construction of PANELSs. A base channel of 75mm x 40mm x 5mm thick shall be provided at the bottom. A minimum of 200 mm between the floor of MV PANELS & Distribution board and lower most unit shall be provided. The PANELS shall be of adequate size with a provision of 20% spare space to accommodate possible future additional switchgear in addition to spare feeders.

Knockout holes of appropriate size and number shall be provided in the PANELSs in conformity with the location of incoming and outgoing cables.

PANELSs shall be provided with removable aluminum plates at top and bottom to drill holes for cable entry at site.

The PANELSs shall be suitable for IP 42 protection.

## 6.2. CIRCUIT COMPARTMENTS

Each circuit breaker, MCCB and switch fuse units shall be housed in separate compartments and shall be enclosed on all sides. Sheet steel hinged lockable door shall be duly interlocked with the ACB/MCCB/switch fuse unit in 'on' and 'off' position. Safety interlocks shall be provided for air circuit breakers to prevent the breaker from being drawn out when the breaker is in 'on' position. The door shall not form an integral part of the draw out position of the ACB. All instruments and indicating lamps shall not be mounted on the ACB compartment door. Sheet steel barriers shall be provided between the tiers in a vertical section. The Knobs for holding the cubicle door in closed position shall be spring operating rotating type and not screwed type.

## 6.3. INSTRUMENT ACCOMMODATION

Separate and adequate compartments shall be provided for accommodating instruments, indicating lamps, control contractors and control fuses etc. These shall be accessible for testing and maintenance without any danger of accidental contact with live parts of the circuit breaker, bus bar and connections.

## 6.4. BUS BARS & BUS BAR CONNECTION

The bus bar and interconnections shall be of electrolytic Copper of 99.9 % purity of rectangular cross sections suitable for full load current for phase bus bars and full rated current for neutral bus bar and shall be extendible on either side. Minimum 200 Amps capacity bus bars shall be provided in the distribution boards. The bus bars and interconnections shall be insulated with PVC heat shrinking sleeves and colour coded. The bus bars shall be supported on unbreakable, nonhygroscopic insulated SMC supports at regular intervals to withstand the forces arising from short circuit in the system. All bus bars shall be provided in a separate chamber and properly ventilated. The current density of copper shall not be more than 1.6 Amps per sq.mm cross sectional area of Bus bar. If Aluminium bus bars are provided the current density of Aluminium shall not be more than 0.8 Amps per sq. mm cross section of Aluminium bus bar. Maximum allowable temperature for the Bus bar to be restricted to 85<sup>o</sup> C.

All bus bar connections in PANELS shall be done by drilling holes in bus bars and connecting by cadmium plated M.S. bolts and nuts. 20% Additional cross section of bus bars shall be provided in all distribution boards to cover up the holes drilled in the bus bars. Spring and flat washers shall be used for tightening the bolts. Automatically operated safety shutters to screen the live cluster when the breaker is withdrawn from cubicle is to be provided.

All connections between bus bars and switches and between switches and cable alley terminals shall be through solid copper strips of proper size to carry full rated current and insulated with PVC heat shrinking sleeves. All the PANELSs shall be completely factory wired, ready for connection. All the terminals shall have adequate current rating and size to suit individual feeder requirements. Each feeder shall be clearly numbered from left to right to correspond with wiring diagram. All the switches and feeders shall be distinctly marked with a small description of the service installed. Minimum width of busbar Alley shall be 300 mm and that of cable alley shall be 450 mm.

## 6.5. TERMINALS

The outgoing terminals and neutral link shall be brought out to a cable alley suitably located and accessible from the PANELS front. The current transformer for instruments metering shall be mounted on the terminal blocks. Cable compartments shall be provided for incoming and outgoing cables with suitable bus bar extension and supports.

## 6.6. WIREWAYS

A horizontal wire way with screwed covers shall be provided at the top to take interconnecting control wiring between different vertical sections.

## 6.7. CABLE COMPARTMENTS

Cable compartment of adequate size shall be provided in the PANELSs for easy termination of all incoming and outgoing cables entering from bottom or top. Adequate proper supports shall be provided in cable compartments to

support cables. All incoming and outgoing switch/MCCB's terminals shall be brought out to terminal blocks in the cable compartment. The switch board shall have in each PANELS thermostatically controlled space heaters/ ventilation fans.

#### 6.8. METERS

All meters shall be housed in a separate compartment and accessible from front only. Lockable doors shall be provided for the metering compartment. The details of other meters and indicating lamps are as described in each switch board and neutral selector switch of appropriate range and scale. Wiring for meters shall be colour coded and labeled with approved plastic ferrules for easy identification. All meters shall be digital.

#### 6.9. CURRENT TRANSFORMERS

Where ammeters are called for CT's shall be provided for current measuring more than 60 Amps. Each phase shall be provided with separate current transformer of accuracy class I and suitable V.A. Burden for operation of associated metering and Relays. Current transformers shall be in accordance with IS:2705-1964 as amended upto date and Cast Resin Type. Tape wound CTS are not acceptable. The name plate of CT's. Shall be fixed in such a way it can be easily readable without dismantling.

#### 6.10. INDICATING PANELS AND METERING EQUIPMENT

All meters and indicating instruments shall be accordance with relevant Indian Standards. The meters shall be flush mounted and drawout type. Indicating lamps shall be neon type and of low burden. Indicating lamps shall be backed up with fuses of 5 Amps and toggle switch.

#### 6.11. EARTHING

Copper earth bars of 25mm x 3mm shall be provided for all PANELS for the full length and connected to the framework of the PANELS.

Provision shall be made for connection from this earth bar to the main earthing bar on both sides of the PANELS.

#### 6.12. PAINTING

All sheet steel work shall undergo a process of degreasing pickling in acid, cold rinsing, phosphating, passivating and then sprayed with a high corrosion resistant primer. The primer shall be baked in an oven. The finishing paint treatment shall be by powder coating.

#### 6.13. LABELS

Engraved anodized aluminium labels shall be provided on all incoming and outgoing feeder switches. Circuit diagram showing the control wiring shall be pasted on inside of the PANELS door and covered with transparent laminated plastic sheet. The Label shall indicate the name of the feeder, the specific area it is feeding, ampere rating and the cable size it is receiving. The Labels shall be provided on the backside of the PANELS in case of back access.

All the PANELSs shall be subject to tests specified in relevant Indian Standards and test certificate shall be furnished.

#### 6.14. SHOP DRAWING

Before fabricating the PANELSs the contractor has to submit shop drawing showing the general arrangements, bill of materials and the wiring diagram for all the PANELSs to the Consultant and get approval from the Consultant.

#### 6.15. INSPECTION

At all reasonable times during production and prior to shipment of equipment the contractor shall provide and secure for Consultant/ Owners representative every reasonable access and facility at their plant for inspection.

#### 6.16. TEST CERTIFICATES

Testing of PANELSs shall be carried out at factory and at site as specified in Indian Standards. The test certificates for the tests carried out at factory shall be submitted in duplicate.

#### 6.17. MINIATURE CIRCUIT BREAKER (MCB)

Miniature circuit breaker shall be quick make and break type and confirm with Indian Standards IS : 8828 - 1978 ( Specifications for Miniature Air Break Circuit breakers for voltage not exceeding 1000V) The housing of MCB's shall be heat resistant and having a high impact strength. The fault current of MCB's shall not be less than 9000 Amps at 230 volts. The MCB's shall be flush mounted and shall be provided with trip free manual operating mechanism "ON" and "OFF" indications.

The MCB contacts shall be silver nickel and silver graphite alloy coated with silver. Proper arc chutes shall be provided to quench the arc immediately. MCB's shall be provided with magnetic fluid plunger release for over current and short circuit protection. The overload or short circuit devices shall have a common trip bar in the case of DP and TPN Miniature circuit breakers. The MCB shall be tested and certified as per Indian Standards prior to installation.

#### 6.18 LV MCCB (Moulded Case Circuit Breakers)

##### 6.18.1 General

1. Moulded case circuit breakers shall be incorporated in the switch board wherever specified. MCCB shall conform to the latest IEC 60947-Part 1&2 & IS 13947:1993 in all respects.

- They shall be of Category A with a rated service breaking capacity (Ics) rating.
- MCCBs shall be available in fixed or plug-in/withdrawable versions as well as in 3-pole and 4-pole versions. For plug-in/withdrawable versions, a safety trip shall provide advanced opening to prevent connection and disconnection of a closed-circuit breaker.
- MCCBs shall be designed for both vertical and horizontal mounting, without any adverse effect on electrical performance. It shall be possible to supply power either from the upstream or downstream side
- MCCBs shall provide class II insulation (according to IEC 60664-1 standard) between the front and internal power circuits.
- Rated insulation voltage shall be 750V AC (50/60 Hz).
- The circuit breaker shall comply with the isolation function requirement of IEC 60947-2 section 7.1.2 to be marked as suitable for isolation/disconnection to facilitate safety of operating personnel while the breaker is in use.
- All MCCBs required as per BOQ shall have Ics – rating not Icu rating.

1.

- Construction

- For maximum safety, the power contacts shall be insulated in an enclosure made of a thermosetting material from other functions such as the operating mechanism, the case, the trip unit and auxiliaries.
- The operating mechanism of MCCBs shall be of the quick-make, quick-break type with fault tripping overriding manual operation. All poles shall operate simultaneously for circuit breaker opening, closing and tripping
- MCCBs shall be actuated by a toggle or handle that clearly indicates the three positions: ON, OFF and TRIPPED in order to ensure suitability for isolation complying with IEC 60947-2
- The operating mechanism shall be designed such that the toggle or handle can only be in OFF position if the power contacts are all actually separated, in OFF position, the toggle or handle shall indicate the isolation position. Isolation shall be provided by a double break on the main circuit
- MCCB shall be equipped with a “push to trip” button in front to test operation and the opening of poles.

1. 6.18.4 Current Limiting, Discrimination & Endurance

- MCCBs shall comprise a device, designed to trip the circuit-breaker in the event of high-value short-circuit currents. This device shall be independent of trip unit.
- The electrical endurance of MCCBs, as defined by IEC 60947-2 standard, shall be at least equal to 3 times the minimum required by the standard
- The MCCB shall employ maintenance free double break contact system to minimize the let-through energies and capable of achieving discrimination up to the full short circuit capacity of the downstream MCCB. The manufacturer shall provide both the discrimination tables (with test certificates) and let-through energy curves.

1. 6.18.5 Accessories

2. MCCB shall be provided with the following accessories, as specified in schedule of quantities.

3. i) Under voltage trip
4. ii) Shunt trip
5. iii) Alarm switch
6. iv) Auxiliary switches

7.

8. All the accessories shall be rated for continuous operation. These Auxiliaries shall be common for the similar type and range of MCCBs.

9.

10. It should be possible to fit MCCBs with a motor mechanism for electrically controlled operation.

6.18.6 Interlocking

1. Moulded, case circuit breakers shall be provided with the following interlocking devices.

2.

3. a) Extended door handle.

4. b) Handle interlock to prevent unnecessary manipulations of the breaker.

5. c) Door interlock to prevent the door being opened when the breaker is in ON position.

6. d) Defeat-interlocking device to open the door even if the breaker is in ON position.

7.

The MCCB shall be current limiting type and comprise of quick make – Break switching mechanism. MCCBs shall be capable of defined variable overload adjustment. All MCCBs shall have adjustable short circuit pick-up.

8. The trip command shall override all other commands.

9. Protection Functions Wherever Specified

- All the MCCBs shall be with microprocessor-based trip units with adjustable Overload & Short circuit protection. Earth fault/Earth leakage protection shall be provided in the MCCB.
- Trip units shall be fully interchangeable type and it should be possible to upgrade the trip unit anytime without any modifications in the installation.
- In case of overload, Pre alarm indication shall be provided on the MCCB.
  
- Trip units shall be adjustable, and it shall be possible to fit lead seals to prevent unauthorized access to the settings.
- Trip units shall comply with appendix F of IEC 60947-2 standard (measurement of rms current values, electromagnetic compatibility, etc.)
  
- Protection settings shall apply to all circuit breaker poles.
  
- Trip units shall be equipped with Thermal memory feature to reduce the stress on the installation in case of repetitive overloads.
- All electronic components shall withstand temperatures up to 125 °C.

6.18.7 Testing

1. a) Original test certificate of the MCCB as per IEC 60947-1 & 2 or IS13947 shall be furnished.
- b) Pre-commissioning tests on the switch board PANELS incorporating the MCCB shall be done as per standard specifications.

7 FIRE DETECTION AND ALARM SYSTEM:-

7.1 SCOPE

The scope of this section covers design, manufacturers, supply, installation, connecting, testing and commissioning of conventional type fire detection and alarm system.

The work include supply, installation, testing and commissioning of:

- a. M S conduit work with all accessories.
- b. Complete wiring in existing concealed/surface conduits
- c. Photoelectric type smoke detectors.
- d. Rate of rise cum fixed temperature heat detectors.
- e. Manual alarm stations.
- f. Response indicators.
- g. Main control and indicating panel/zonal panel.

A high degree of operational safety, high quality and well-designed detectors, signal panels and auxiliary equipment shall be accepted. Supplier shall confirm that the electronic components used in alarm and indicating panels are of standard manufacturers and are approved type, also the name of the manufacturer shall be indicated.

The Contractor shall obtain clearance and approval form the Local Fire Authorities, the insurance company ensuring the building or any other agencies whom approval is required.

7.2 STANDARDS

For Spacing of detectors	BS	:	Code of Practice CP 1019, Section 2.7
For sensitivity of smoke detector	BS	:	5446 - 1977
For control and indicating panel	IS	:	2189 - 1988
For smoke Detector	IS	:	11360 - 1985
For Heat Detector	IS	:	2175 - 1988

### 7.3 OPERATING VOLTAGE

220 volts AC + 10% 50 cycles (single phase) and 24 volts DC +- 10%

### 7.4 DETECTORS IN GENERAL

#### 7.4.1 COMPATIBILITY

All automatic fire detectors shall be interchangeable without requiring different mounting bases nor alternations in the signal panel.

#### 7.4.2 RESPONSE SPECTRUM

Combustion gas detectors shall respond to both visible and invisible aerosols, size and colour of the aerosols shall not have a decisive influence on the response of the detector.

#### 7.4.3 SENSITIVITY

On average, 30 mgr of burned material per cu.m (as measured in a 1 cu.m chamber) shall release an alarm.

#### POWER CONSUMPTION

Each detector shall use the minimum of power, for economic circuits, so that it shall be possible to connect atleast 20 detectors per zone. Distance upto 1000 meters from detector to signal panel shall not influence the number of detectors per zone.

#### BUILT-IN-RESPONSE INDICATOR

Each detector shall incorporate indicator "LED" at the base of the detector which shall light up on actuation of the detector to locate the detector which is operated. The detector shall not be affected by failure of the response indicator lamp.

#### RESPONSE INDICATORS

It shall be possible to provide a secondary response indicator for the detector outside the closed room.

#### MAINTNEANCE

All detectors shall be fitted either with plug-in system or bayonet type connections only, from the maintenance and compatibility point of view.

#### CONSTRUCTION

The detector shall be vibration and shock proof. When disassembling for cleaning purpose, its components must not be damaged by static over voltage.

#### ATMOSPHERIC AND THERMAL DISTURBANCES

The detector shall also be designed as to be practically immune to environmental criteria such as air currents, humidity, temperature fluctuations, pressure and shall not release false alarm.

#### CONTINUOUS OPERATION

An alarm release shall not affect a detector's good functioning. After resetting the alarm, the detector shall resume operation without re-adjustment of any kind.

#### DAPTABILITY TO AMBIENT CONDITIONS

Detectors shall be designed for adaptability to humid and explosion endangered locations.

### 18 PHOTOELECTRIC SMOKE DETECTORS

Smoke detectors shall connect with two wires to one of the Fire Alarm Panel Loops. The detectors shall use the photoelectric (light-scattering) principal to measure smoke density and shall, on command from the control panel, send data to the panel representing the analog value for smoke density. The detectors shall be ceiling mounted type and

shall include a twist-lock base.

The detectors shall provide dual alarm and power LEDs. Both LEDs shall flash under normal conditions, indicating that the detector is operational and in regular communication with the control panel. Both LEDs may be placed into steady illumination by the control panel; indicating that an alarm condition has been detected. An output connection shall also be provided in the base to connect an external remote alarm LED.

The area covered by each smoke detector shall be as per IS-2189.

Detectors shall be suitable for an operating temperature 0 degree C to 55 degree C and Relative humidity of 0% to 95%. Detectors shall be suitable for a supply voltage of 17 to 28 V DC without affecting the sensitivity. The detector shall have the approval of UL/FM/VDS/LPC only.

#### THERMAL DETECTORS

Thermal detectors shall connect with two wires to one of the Fire Alarm Panel loops. The detectors shall use an electronic detector to measure thermal conditions caused by a fire and shall, on command from the control panel, send data to the panel representing the level of such thermal measurements. The detectors shall be ceiling-mounted type and shall include a twist-lock base.

The detectors shall provide dual alarm and power LEDs. Both LEDs shall flash under normal conditions. Both LEDs may be placed into steady illumination by the control panel, indicating that an alarm condition has been detected.

Detectors shall be suitable for an operating temperature 0 degree C to 22 degree C and relative humidity of 0% to 95%.

Detectors shall be suitable for a supply voltage of 17 to 28 V DC without affecting the sensitivity.

The detector shall have the approval of UL/FM/VDS/LPC only.

#### 7.6 MANUAL CALL STATIONS

Manual Call stations shall be provided to connect to the Fire Alarm Panel loops.

Manual stations shall be constructed of high impact LEXAN sheet with clearly visible operating instructions provided on the cover. The word FIRE shall appear on the front of the stations in raised letters. Press/back stations with reset table capacity shall be acceptable.

Stations shall be suitable for surface mounting as shown on the plans, or semi-flush mounting, and shall be installed not less than 42 inches, nor more than 48 inches above the finished floor unless otherwise specified by applicable building codes.

#### 7.7 RESPONSE INDICATOR

Response indicator shall be LED (light emitting diode) type and shall indicate when a detector senses the fire.

#### 7.8 REPEATER PANEL

Repeater panels are to be provided at remote location for monitoring the health of FAS. It should have 2-line 40 inches character display along with CEO status indicator. Battery backup shall be provided as an in-built feature and all information will be presented in clear English language. It shall be suitable for operation from 0 degree C to 49 degree C and shall be flush mounted.

#### 7.9 ELECTRONIC HOOTERS

All Hooters should be able to provide at least a minimum of 3 different tones, which should be user configurable. The minimum decibel level of each hooter should be 90db at 1 mtr. All hooters should be UL/FM listed.

The Electronic Hooters shall be housed in MS enclosure of 1.5 mm sheet metal.

The Hooters shall be with built on oscillator & amplifier.

The Hooters shall give wailing sound whenever it received 24 V supply from panel on receipt of Fire signal.

The MS box shall be painted with Fire Red (Power Coated)

#### 7.10 MAIN FIRE ALARM CONTROL PANEL

##### Control Panel

The control cabinet shall be dust proof and shall be provided with a glass door with lock and key to prevent tampering by unauthorized persons.

The control circuit shall consist of glass epoxy (PCB) printed circuit board, silver plated and treated with protective layer of special lacquer for protection against corrosion.

The alarm circuitry shall be 100% solid state without the use of any relays anywhere in zone card.

The zone cards shall be modular and interchangeable.

Every zone shall have individual control for test acknowledge and any zone shall be isolated without effecting the working of the other zones in the panel.

Sounder silencing control shall be provided which shall remain in visual indication at the same time making the panel from to receive alarm from any other zone without the need for resetting the entire panel.

Silencing switches/push buttons – the system shall be so designed that once an alarm has been given it shall continue till the alarm sounder is switched off. The silencing switches/push buttons in their 'OFF' position shall give an indication of this fact on the main control panel or transfer the alarm signal to supervisory sounders under the supervision of the responsible person so that they may put use of the smallest number of call points. Operation of silencing switch shall not prevent sounding of alarm from any other zone simultaneously.

Central control and indicating panel shall be suitable for conventional Fire Detection and Alarm System and shall comply with IS:2189-1988.

Control panel shall support the following Fire-Detection components.

Smoke Detectors

Detectors (Both fixed & rate of temperature rise type)

Manual Call Stations

System shall be completely backed up against Mains failure for at least 8 hours and shall be suitable for the following types of batteries.

Lead acid Maintenance free.

Lead acid non-maintenance free

Lead acid semi-maintenance free

Nickel Cadmium.

System shall be self-diagnostic and shall cover the following:

Components/Modules of the fire panel.

Faulty detectors

Missing detectors

Open circuit short circuit conditions of the detector cable.

Suitable indication shall be given on the panel.

Zone wise annunciation of alarm by using:

Buzzer Sounders

## 7.11. BATTERY

Suitable rating ampere Hours 24 Volts DC sealed maintenance free batteries shall be provided for Fire Detection and Alarm System. The battery rating is indicative only. It shall be sized by bidder to cater to all momentary and short time loads in addition to supplying the continuously rated loads for a duration of 8 hours. However minimum size shall be 65 AH.

### Battery Charger

Bidder shall furnish the battery charging system complete with all necessary accessories such as transformer, rectifier, switches, fuses, starters, contactors, ammeter, voltmeter, protections and other, devices for trouble free operation.

### Construction features

Housing of battery charger shall be 2 mm thick CRCA steel sheet cabinet for indoor installation and shall be floor mounted type. The cabinet shall be folded and braced as necessary to provide a rigid support for all components. Louvers shall be provided in the cabinet for ventilation. PVC sheets of 3 mm thick shall be provided on the selves on which the batteries are to be placed.

### Input

240 volts AC 50 cycles, single phase with tapings of 0-200-220-240-260 volts on the primary side of the transformer.

### Output

DC output shall be 24 volts. DC bridge rectifier shall be of silicon type, having full wave rectification. Suitable contactor, relay, reset shall be provided as required.

## 7.12 CABLES

All PVC insulated FRLS copper conductor stranded cables shall be 650 volts grade and shall generally conform to IS-1554-1988 and meet the signal cabling requirement of the system manufacturer.

Strands of cables shall not be cut to accommodate & connect to the terminals. Terminals shall have sufficient cross-sectional area to take all the strands.

Cables shall be laid by skilled and experienced workmen using adequate rollers to minimize stretching of the cable. The cable drums shall be placed on jacks before unwinding the cable. Great care shall be exercised in laying cables to avoid forming kinks. At all changes in direction in horizontal and vertical planes, the cable shall be bent smooth with a radius as recommended by the manufacturers. All cables shall be laid with minimum one diameter gap and shall be clamped at every metre and shall be tagged for identification with aluminium tag and clamped properly. Tags shall be provided at both ends and all changes in directions both sides of wall and floor crossings. All cable shall be identified by embossing on the tag the size of the cable, place of origin and termination.

These shall be measured on linear basis including the fittings required like, end termination junction box.

## 8.3 PUBLIC ADDRESS DEVICES

### 8.3.1 Speakers:

All speakers shall operate on 25 VRMS or with field selectable output taps from 0.5 to 2.0 Watts.

Speaker in corridors and public spaces shall produce a nominal sound output of 84 dBA at 3 meters.

Frequency response shall be a minimum of 400 HZ to 4000 HZ.

The back of each speaker shall be sealed to protect the speaker cone from damage and dust.

### Fixed Emergency Telephone Handset

The telephone cabinet shall be painted red and clearly labeled as "Emergency Telephone". The cabinets shall be located where shown on drawings.

The handset cradle shall have a switch connection so that lifting the handset off of the cradle shall send a signal to the fire command center which shall audibly and visually indicate its on-line (off-hook) condition.

On activating the remote phone, the phone earpiece shall sound a telephone ring signal until the master handset is lifted.

The two-way emergency telephone system shall support a minimum of seven (7) handsets online without degradation of the signal.

## POINT WIRING

The rates for all point wiring items shall include:

1. Conduits, Conduit specials, bushes and other fittings concealed or exposed as called for.
2. Embedding conduit and allied fittings including the outlet boxes in walls, floors etc., during construction and/or in chases including cutting chases and making good with cement mortar as necessary in the case of concealed conduit work.
3. Providing and fixing approved fixing devices, saddles and grouting the same as required for exposed conduits.
4. Fabrication and Supply of G. I. boxes for switches, ceiling fan hooks, Exhaust fans outlet and lighting fixtures with 1.6 mm thick sheet steel.
5. Providing and fixing junction boxes with 3mm Hylam or 3mm/5mm thick Perspex sheet cover duly painted from inside to match the colour of the walls. All Junction boxes shall be MS only.
6. All fixing accessories such as clips, brass screws/brass washer's awl plugs etc.
7. All work & material necessary (including circuit wiring from DB to first tapping point of each circuit with 2.5 sq. mm wires) in complete wiring of a switch circuit of any length from the distribution board to the following via the switch:
  - a) Ceiling rose
  - b) Connector
  - c) Back plate
  - d) Socket outlet
  - e) Lamps Holder
  - f) Any other terminal outlet
  - boxes g) Ceiling fan and Exhaust fan
8. Switch, socket outlet as called for.
9. Cable/wire as required up to lamp holder.
10. All metal boxes and boards concealed, or surface mounted including those required for housing fan regulators.
11. All accessories necessary to complete wiring as specified.
12. FRLS PVC Insulated stranded Copper conductor earth wire for fixtures, switch outlet boxes and third pin of 5/15 Amps. socket to common earth.
13. Painting all exposed M.S. conduits, outlet boxes and junction boxes.
14. M.S. conduit for concealed and exposed wiring.
15. 2 mm dia G.I. pull wires in conduit work, wherever necessary.
16. The switch plate shall be made of I.S.I. grade Urea Formaldehyde Moulding powder. The base of the switches shall be made from high heat resistant phenol formaldehyde powder. The cost of switches shall include the cost of cover plates, cadmium fixing screws etc.  
The switches/sockets shall be rocker operated.
17. Separate Earth wire shall run along with each circuit both for power and light circuits.
18. Cutting of floor and making good for carrying conduits also.
19. Numbering of Circuits with ferrules for all circuits at both ends.
1. Providing 15 Amps capacity Bakelite terminal Blocks for terminating the phase, neutral and earth wire at each fixture location.
10. PVC insulated copper conductor wire ends before connection shall be properly soldered (at least 15 mm length) with special Cu solder for copper conductor or shall be properly crimped with copper lugs/sockets as the case may be. Strands of wires shall not be out for connecting to the terminals. All stands of wires shall be soldered at the end before connection. The connecting brass-screws shall have flat ends. All looped joints shall be soldered and connected through terminal block/connectors.
10. Provide embossing on the sockets engraving "UPS" and "RAW"

## CONDUITING FOR TELEPHONE & COMPUTER SYSTEM

The rates for conduit work shall include:

1. All necessary specials and fittings.
2. M. S. inspection, junction and outlet boxes as required.
3. 3/5 mm thick Perspex sheet covers for inspection & junction boxes.
4. All fixing accessories such as clips, nails, brass screws/brass washers, etc.
5. 2 mm dia G.I. pull wires in conduit work, wherever necessary.
6. Providing and fixing approved saddle, hooks and grouting the same as required in the case of all exposed conduit work.
7. Embedding conduit and allied fittings including the outlet boxes in walls, floors etc., during construction and/or in chases including cutting chases and making good with cement mortar as necessary in the case of concealed conduit work.
8. Painting all inspection, junction and outlet boxes.
9. FRLS PVC conduit for concealed conduit wiring.
10. Painting of Hylam/perspex sheet cover from inside to suit the colour of the surrounding wall with two coats of paint.
11. Supply and fabrication of MS Zinc passivated outlet boxes.
12. The outlet cover plate for Telephone outlets shall be made of I.S.I. grade Urea Formaldehyde Moulding powder. The cost of outlets shall include the cost of cover plates, cadmium fixing screws etc. also.
13. Numbering of wires on both ends of the wires for easy identification with PVC ferrules.

## EARTHING

The rates for earthing items include:

1. All fixing accessories such as brass saddles, brass screws, raw plugs etc.
2. Jointing by riveting in case of copper earth strips (2 per joint) and by welding in case of GI strips.
3. Cutting chase, making holes and making good the same wherever required.
4. All masonry work including earth work for earthing stations, earthing tapes and wires.
5. Effecting adequate and proper interconnections.
6. Use of copper thimbles for all wire terminations in the Distribution Boards, switches and sockets.

## CABLES, MAINS AND SUB-MAINS

The rates for all items of work shall include:

1. Embedding conduits and allied fittings in walls, floors, etc., during construction and/or in chases including

cutting chases and making good as necessary in the case of concealed conduit work.

2. Providing and fixing approved saddles, hangers, trays etc., and grouting the same as required for exposed conduits where called for. Providing dash fasteners for the threaded MS down rods (primer coated) used for hanging the cable \trays.
3. Providing and fixing junction boxes with 5 mm thick 'Hylam' sheet covers.
4. Effecting adequate and proper connections at terminations.
5. Ensuring that provision is left in various buildings components and trenches as the work proceeds, for incorporation of cable supports at a later date.
6. Providing all fixing accessories such as clamping devices, nuts and bolts, screws etc.
7. Clamping to supports where laid in trenches.
8. Excavation of trenches and bringing the trenches to exact level as required.
9. Providing sealing compound, thimble, solder etc., at joints and terminations as called for.
10. Providing proper supports for cable terminal boxes as called for.
11. Wherever cables pass through walls, ceiling, paved area or below roads provide sleeves/ hume pipes and making good as necessary.

#### DISTRIBUTION BOARDS

The rates for the following items of work generally include:

1. The supporting rigid steel framework.
2. 1.6 mm thick MS boxes complete with dust proof and vermin proof covers and locking arrangements, mounted flush with surfaces.
3. All fixing accessories such as dash fasteners, bolts, nuts, screws, etc. as required.
4. Building into masonry/concrete work including all necessary cutting and grouting with cement mortar 1:2.
5. Effecting adequate and proper connections.
6. Effecting proper bonding to earth.
7. Painting/lettering on switches and distribution boards the location they serve and providing on each board its circuit diagram.
8. Touching up all damaged paint over exposed work with one coat of red oxide primer and two finishing coats of approved synthetic enamel paint.
9. Main Distribution Board and Final Distribution Boards shall be fabricated by Contractor with the specified equipment.
10. Provide 6 Amps. SP MCB for Light Points Circuits, 20 Amps. SP MCB for Power Circuits and 32 Amps. SP MCB for 1.5 Ton AC Unit.

#### SUPPLY & FIXING OF LIGHTING FIXTURES

The rate for fixing of lighting fixtures and fans shall include:

1. Receiving the fixtures from the Owner's stores and assemble the same at site and testing the fixture before fixing.
2. All components that may be required to make the installation complete in all respects such as:
  - a. Suitable length of down rod, hanger and connecting wires, where called for.
  - b. Wires for connecting the fixtures to the point through connector blocks.
  - c. All wood and metal blocks to serve as base of fixtures.
  - d. Bonding with common earth wires.
3. Drilling holes in supports where required.
4. Fixing clamps, GI bolts and nuts, clips, brass screws, dash fasteners and other fixing accessories as required, including leaving necessary provision for fixing at time of concreting.
5. Approved enamel painting for hanger rods, clamps and other components and fixing accessories as called for.
6. Testing and commissioning of all fixtures and fans after installation.
7. The lighting fixtures shall be suitable for 230 Volts, single phase 50 cycles A.C. supply system.
1. Incandescent lamps shall be 100 Watts (maximum) and fluorescent lamps shall be 18 watts and 36 watts.
9. Use G.I. suspenders and clamping to the slab with dash fasteners (4 per fitting), including turn buckle arrangements for adjustable heights for hanging. They should be the same suspenders as used for hanging the False Ceiling grid ceiling.
10. The contractor to mark the size of light fittings, speaker and fire alarm components on the false ceiling for the interior contractor to cut holes.

#### SPECIFICATIONS FOR SERVICES

##### - General

1.1 The drawings for services are diagrammatic but shall be followed as closely as actual construction permits. Any deviations from the drawings shall be in conformity with Consultant Ural and structural drawings. The dimensions designated by the manufacturers shall take precedence over the drawings.

- At completion of work the Contractor shall submit one set of tracings and two sets of prints of "As-Built-Drawings". These drawings shall, among others, include invert levels, pipe runs, diameters, location of valves, access panels, layout of equipment, piping connections and such other information for maintenance & future extensions. Guarantees given by manufacturers shall be assigned to the Employer along with names & addresses of manufacturers, suppliers and information about spare parts.

- All site test shall be carried out with prior intimation to the Bank Engineer / Consultant. All defects shall be rectified, and tests conducted again to the satisfaction of the Bank Engineer / Consultant. In addition to the test required by the specifications, the Contractor shall also conduct tests required by the Consultant and by the Municipal or other Authorities.

- All work shall be executed by competent and licensed persons. The contractor shall maintain liaison with Municipal and other controlling Authorities. He shall obtain their approvals and certificates as required by the bye - laws at appropriate stages.

- No cutting / chasing shall be done in load bearing structural members without prior approval of the Asstt. Engineer. Sleeves and openings shall be provided during the progress of construction in preference to cutting at later date.

- The Consultant may require typical mockup(s) to be installed in advance for approval. Undamaged materials from the mockup shall be allowed to be reused in the work.
  - Unless otherwise described in the item CI / SCI pipes and fittings shall be a spigot and socket type.
  - G.I. pipe spouts shall be paid as per item of G.I. pipes (internal work). Cutting and making good is included. The free ends may be skew cut.
  - Wherever use of G.I. pipes is called for the same shall be medium class (class – B)
  - Materials:
- 2.1 The materials shall conform to the specifications and in absence thereof to Indian Standards. The products should bear the ISI Mark.
- 2.2 The makes of materials for use in this work are broadly approved as per list given below. The Contractor shall, however, get particular makes and samples approved before ordering:
- 2.3 Notwithstanding any interim or final approval the Contractor remains responsible for satisfactory performance of all fittings & fixtures. The liability of the Contractor is not limited by any approval of the make of materials.
- 2.4 The item rate of mirror includes extra packing piece of AC plain sheet, where required due to offset between plaster & glazed tiles surface.
- Testing
  - The sand cast iron soil, waste and vent pipes and fittings including joints shall be tested by pumping smoke into the pipe at the lowest end.
  - All G.I pipes and fittings including joints shall be tested to hydraulic pressure of 6 kg / cm<sup>2</sup> (60 meters) avoiding water hammer. The test pump having been stopped the test pressure should maintain without loss for at least half an hour. The pipes and fittings shall be tested in sections as the work of laying proceeds keeping the joints exposed for inspection during the testing.
  - All stone ware pipes shall be tested with water pressure of 1.5m head of water at the highest point of the section under test.

**ARTICLES OF AGREEMENT**

(On non-judicial Stamp Paper of Rs. 500/- or as per latest Govt. Rules)

ARTICLES OF AGREEMENT made the \_\_\_\_\_ date of \_\_\_\_\_ between STATE BANK OF INDIA, having its office at Mumbai hereinafter called "the Client" of the One Part and

WHEREAS the STATE BANK OF INDIA is desirous of

\_\_\_\_\_ and has caused specifications describing the work to be done to be prepared by STATE BANK OF INDIA.

AND WHEREAS the said Drawings numbered \_\_\_\_\_ to \_\_\_\_\_ inclusive, the Specifications and the Schedule of Quantities have been signed by or on behalf of the parties hereto.

AND WHEREAS the Contractor has agreed to execute upon and subject to the Conditions set forth herein and to the Conditions set forth herein in the Special Conditions and in the Schedule of Quantities and Conditions of Contract (all of which are collectively hereinafter referred to as "the said conditions") the works shown upon the said Drawings and / or described in the said Specifications and included in the Schedule of Quantities at the respective rates therein set forth amounting to the sum as therein arrived at our such other sum as shall become payable there under (hereinafter referred to as "the said Contract Amount.)

NOW IT IS HEREBY AGREED AS FOLLOWS:

- 1) In consideration of the said Contract Amount to be paid at the times and in the manner set forth in the said Conditions, the Contractor shall upon and subject to the said Conditions execute and complete the work shown upon the said Drawings and described in the said Specifications and the priced Schedule of Quantities.
- 2) The Employer shall pay to the Contractor the said Contract Amount, or such other sum as shall become payable, at the times and in the manner specified in the said Conditions.
- 3) The term "The Architects" in the said Conditions shall mean the STATE BANK OF INDIA, or in the event of their ceasing to be the Architects for the purpose of this Contract for whatever reason, such other person or persons as shall be nominated for that purpose by the Employer, not being a person to whom the Contractor shall object for reasons considered to be sufficient by the Employer, PROVIDED ALWAYS that no person or persons subsequently appointed to be Architects under this Contract shall be entitled to disregard or overrule any previous decisions or approval or direction given or expressed in writing by the outgoing Architects for the time being.
- 4) The said Conditions and Appendix thereto shall be read and construed as forming part of this Agreement, and the parties hereto shall respectively abide by submit themselves to the said Conditions and perform the Agreements on their part respectively in the said Conditions contained.
- 5) The Plans, Agreements and Documents mentioned herein shall form the basis of this Contract.
- 6) This Contract is neither a fixed lump-sum contract nor a piece work contract but a contract to carry out the work in respect of the entire building complex to be paid for according to actual measured quantities

at the rates contained in the Schedule of Quantities and Rates or as provided in the said Conditions.

- 7) The Contractor shall afford every reasonable facility for the carrying out of all works relating to CIVIL WORKS, installation of lifts, Telephone, electrical installations, fittings air conditioning and other ancillary works in the manner laid down in the said Conditions, and shall make good any damages done to walls, floors, etc. after the completion of his work.
- 8) The STATE BANK OF INDIA reserves to itself the right of altering the drawings and nature of the work by adding to or omitting any items of work or having portions of the same carried out without prejudice to this Contract.
- 9) Time shall be considered as the essence of this Contract and the Contractor hereby agrees to commence the work soon after the Site is handed over to him or from 14<sup>th</sup> day after the date of issue of formal work order as provided for in the said Conditions whichever is later and to complete the entire work within **60 days** subject to nevertheless the provisions for extension of time.
- 10) All payments by the SBI under this Contract will be made only at Mumbai.
- 11) All disputes arising out of or in any way connected with this Agreement shall be deemed to have arisen at Mumbai and only the Courts in Mumbai shall have jurisdiction to determine the same.
- 12) That the several parts of this Contract have been read by the Contractor and fully understood by the Contractor.

IN WITNESS WHEREOF THE EMPLOYER and the Contractor have set their respective hands to these presents and two duplicates hereof the day and year first hereinafter written.

SIGNATURE CLAUSE

SIGNED AND DELIVERED by the

\_\_\_\_\_ By the  
(Employer)

hand of Shri \_\_\_\_\_

\_\_\_\_\_  
(Name and Designation)

(Signature of Employer)

In the presence of :

1) Shri / Smt. \_\_\_\_\_

(Signature of Witness)

Address \_\_\_\_\_

(Witness) \_\_\_\_\_

SIGNED AND DELIVERED by the

\_\_\_\_\_ by the  
(Contractor)

(Signature of Contractors)

in the presence of :

Shri / Smt. \_\_\_\_\_

(Signature of Witness)

Address \_\_\_\_\_

\_\_\_\_\_  
(Witness)

## SAFETY CODE

1. First aid appliances including adequate supply of sterilized dressing and cotton wool shall be kept in a readily accessible place.
2. An injured person shall be taken to a public hospital without loss of time, in cases when the injury necessitates hospitalization.
3. Suitable and strong scaffolds should be provided for workmen for all works that cannot safely be done from the ground.
4. No portable single ladder shall be over 8 meters in length. The width between the side rails shall not be less than 30 cm. (clear) and the distance between two adjacent running shall not be more than 30 cm. When a ladder is used an extra Mazdoor shall be engaged for holding ladder.
5. The excavated material shall not be placed within 1.5 meters of the edge of the trench half of the depth of trench whichever is more. All trenches and excavations shall be provided with necessary fencing and lighting.
6. Every opening in the floor of a building or in a working platform be provided with suitable means to prevent the fall of persons or materials by providing suitable fencing or railing whose minimum height shall be one meter.
7. No floor, roof or other part of the structure shall be so overloaded with debris or material as to render it unsafe.
8. Workers employed on mixing and handling material such as asphalt, cement, mortar, concrete and lime shall be provided with protective footwear and rubber hand gloves.
9. Those engaged in welding works shall be provided with welders' protective eye shield and gloves.
10. (i) No paint containing lead or lead products shall be used except in the form of paste ready made paint.  
(ii) Suitable facemasks should be supplied for use by the workers when the paint applied in the form of spray or surface having lead paint dry rubbed and scrapped.
11. Overalls shall be supplied by the contractor to the painters and adequate facilities shall be provided to enable the working painters to wash during cessation of work.
12. Hoisting machines and tackle used in the works including their attachments anchor and supports shall be in perfect condition.
13. The ropes used in hoisting or lowering material or as a means of suspension shall be durable quality and adequate strength and free from defects.

TABLE-I

**PROFORMA FOR HINDRANCE TO WORK**

Name of Work :  
Date of Start of work :  
Name of Contractor :  
Period of Completion :  
Agreement No.:  
Dt. of Completion of work :

S.No.	Nature of Hindrance	Date of Occurrence of Hindrance	Date of which Hindrance was removed	Period of which Hindrance existed	Signature of Site Engineer	Signature of Bank / Architects Representative
1	2	3	4	5	6	7

TABLE-II  
**PROFORMA FOR RUNNING A/C BILL**

- i. Name of Contractor/Agency :  
 ii. Name of Work :  
 iii. S.No. of this Bill :  
 iv. No. & Date of previous Bill :  
 v. Reference to Agreement No. :  
 vi. Date of Written order to commence :  
 vii. Date of Completion as per Agreement:

S.No.	Item Description	Unit	Rate (Rs.)	As per Tender	
				Quantity	Amount (Rs.)
1	2	3	4	5	

Upto Previous R.A. Bill		Up Date (Gross		Present Bill		Remarks
Quantity	Amount (Rs.)	Quantity	Amount (Rs.)	Quantity	Amount (Rs.)	
6		7		8		9

Note: 1. If part rate is allowed for any items, it should be indicated with reasons for allowing such a rate since previous bill

2. If ad-hoc payment is made, it should be mentioned specifically.

\_\_\_\_\_  
 \_\_\_\_\_  
 Net Value

**CERTIFICATE**

The measurements on the basis of which the above entries for the  
Running Bill No. ----- were made have been taken jointly on -----  
-----

\_\_\_\_\_ and are recorded at pages \_\_\_\_\_ to \_\_\_\_\_ of measurement book No. \_\_\_\_\_  
\_\_\_\_\_.

.....

Signature and date of  
Contractor

.....

Signature and  
date of Architects  
Representative  
(Seal)

.....

Signature and date of  
Site Engineer

The work recorded in the above-mentioned measurements has been done at the site satisfactorily as per  
tender drawings, conditions and specifications.

.....

Architect

.....

Signature and  
Date of Site Engineer

TABLE-III  
**MEMORANDUM FOR PAYMENT**

R/A BILL NO.

1.	Total value of work done since previous bill (A)	Rs.-----
2.	Total amount of secured advance due since Previous Bill (B)	Rs.-----
3.	Total amount due since Previous Bill (C) (A+B)	Rs.-----
4.	PVA on account of declaration in price	Rs.-----
5.	of Steel, Cement and other materials and labour as detailed in separate statements enclosed.	
	Total amount due to the Contractor	Rs.-----

**OBJECTIONS:**

i)	Secured Advance paid in the previous	Rs.----- R/A
ii)	Retention money on value of works astenders up to date amount Rs.	Rs.----- per accepted
	Less already recovered	Rs.-----
	Balance to be recovered	Rs.-----
iii)	Mobilization Advance, if any	
(a)	Outstanding amount (principal + interest) as on date	Rs.-----
(b)	To be recovered in this bill	Rs.-----
iii.	Any other Department all materials cost to be recovered as per contract, if any	Rs.-----
iv.	Any other Departmental service charges to be recovered if any, as per contract (water, power etc.) enclose statement.	Rs.-----
	Total Deduction as per contract (F)	Rs.-----

Adjustments, if any-----Rs -- Amount less received by Contractor in  
----- R/A Bill (as per statement of Contractor)  
P.V.A. Rs. --  
Total amount payable as per contract (E+F+G)Rs. -----  
(Rupees in words)

The bill amount to Rs (both figures and words) has been scrutinized by us after due checking of the measurements of work as required and is recommended for payment.

Date:

Signature of Architect with Seal

The bill amount to Rs certified by Consultants has been scrutinized by me after due test checking of measurements of works as required and is recommended for payment for an amount of Rs.....

Date:..... Signature of Owners Engineer

**STATUTORY DEDUCTION:**

i)	Total Amount due(E)	Rs.-----	
ii)	Less I.T .Payable	Rs.-----	
iii)	Less S.T. Payable	Rs.-----	
	Net Payable		Rs.-----

This figures given in the Memorandum for payable has been verified and bill passed for payment.....(in words and figures)

Date: .....

.....

Signature of the Competent Officer

**RECOMMENDED MAKE TO BE USED FOR THE ELECTRICAL & ALLIED WORKS OF BRANCH & E-LOBBY AT  
STATE BANK OF INDIA, KHANAURI-50188.(PB) .**

<b>ELECTRICAL LIST OF APPROVED MAKES OF MATERIALS</b>	
1	PVC/MS CONDUIT PIPE (ISI) MARKED : BEC / PRECISION / AKG / SETIA/CAP
2	WIRES 1100V GRADE FR/FRLS MULTI STRANDED ONLY-ISI : FINOLEX/ SKYTON/ POLYCAB/ BONTON/ RR KABEL/KEI/RELISONS/ESC
3	CABLES 1100V PVC INSULATED FRLS XLPE : SKYTON/ BONTON/RELISONS/ KEI/ GRANDLAY/POLYCAB/FINOLEX/ESC
4	MCBS, MCCBS & ELCBS : SCHNIDER/ LEGRAND/ L&T-HAGER/ ABB/ C&S/HPL/
5	MOULAR SWITCH, SOCKET, PLATES, BOXES & OTHER ACCESSORIES (MDEL MENTIONED) : LEGRAND- Linc/ Mosaic/ CRABTREE-Athena/ PHILIPS-Elite / MK - Wraparound/ North West- Stylus only /Anchor – Woods/Viola/ Simon-Vivid-38/ Great White-Myraha
6	FLUORESCENT/LED/CFL LUMINAIRES : PHILIPS/CROMPTON/ BAJAJ/TRILUX/ /HAVELLS /HELONIX/WIPRO/EVEREADY/HPL
7	METAL CLAD SOCKET OUTLETS : ABB/ L&T/ LEGRAND/ NORTH WEST/C&S
8	TELEPHONE CABLE : DELTON/AMP/D-LINK/FINOLEX
9	BAKELITE SHEET : HYLAM / FORMICA/
10	SOLDERLESS LUGS / FERRULES : DOWELL/
11	CABLE GLANDS : COMET /GRIPWEL/ DOWEL
12	TAG BLOCK (TELE) : KRONE
13	DISTRIBUTION BOARDS (DOUBLE DOOR TYPE) : INDOASIAN/SCHNIDER/ LEGRAND/ L&T-HAGER/ ABB/ C&S/
14	JOINTING KITS/ CONNECTORS : SCREWLESS WAGO & CONTROLS (I) LTD/3M/RPG
15	METERING EQUIPMENTS : RISHAB/ AE/ CONZERV/L&T/SECURE
16	ASS/VSS : KAYACEE/ L&T/
17	FANS : Crompton/BAJAJ/USHA/Havells/Orient
18	LAN & VOICE ; AMP/ D-LINK
19	VOLTAGE STABILIZER & AC TIMER : RITLINES/ BLUE BIRD/ LOGICSTATE/ INLINE/V- GAURD/SERVOKON/SERVEL/RUPTRONICS
<p><b>NOTE: Above makes of equipment are approved subject to their meeting the specifications. The contractor however shall seek approval of specific make from Consultant/ Bank's Engineer before commencing the work. The decision of Consultant/ Bank's shall &amp; binding on the contractor in this respect. Any other make of the equipment not specified shall be got approved by the Consultant/ Bank's as per requirement.</b></p>	

## RECOMMENDED MAKE TO BE USED FOR THE ELECTRICAL & ALLIED WORKS OF BRANCH & E-LOBBY AT STATE BANK OF INDIA, KHANAURI-50188.(PB) .

### AIR CONDITIONING LIST OF APPROVED BRANDS / MAKES

One of the following make of the material shall be used. The contractor will have to get the sample approved from the Consultant/ Bank's Engineer whose decision shall be binding on the contractor. The condition is also applicable for any material, not mentioned in the specification or schedule of work. No deviations are allowed in these even during/ after Tender.

GSS Sheet	:- Jindal / Tata / Sail
Factory Made Ducts	:-Rollastar / Nutech
Propeller fans	:-GE Alsthom / Crompton/ Carryaire
Flexible pipe connection	:-Resistoflex / Dunlop
ExtrudedAluminum Grilles /Diffusers	:- Pine air/Balance/Tristar/carryaire
Firedampers / Volume Control Dampers	:- Carryaire/Pine air/Balance/ Tristar
Flexible insulated ducts	:- CARYAIRE / ATCO/ MAPRO
Fibre glass	:- OWENS CORNING/ UP TWIGA
Extruded Polystyrene Board	:- SUPREME
Cross linked polyethylene	:- SUPREME/A-Flex/Aeroflex
Class 'O' Nitrile rubber insulation EUROBATEX / ARMACELL/A- Flex	:- SUPREME /K-FLEX / SUPERLON /
Copper Pipe Line / Shree Shayam	:-RAJCO / MANDEV / MAXFLOW / Total
PVC PIPE	:- SETIA/ FINOLEX/ PRAKASH/ SURYA
Conduit of Electrical wires	:- AKG, SETIA, BEC
Expanded polystyrene	:- Styrene Packing / Indian Packing
Vibration Isolation Spring	:-Dunlop / Resistoflex
Paints	:-ICI / Asian
Dash Fasteners	:-Canon / Fisher / TKS/Hilti
Welding Rods	:-Advani / L&T
ACB, M.C.B. & MCCB	:- L&T / GE / Crompton
Power/Control Cable	:- ICC/ CCI/ Gloster / Grandlay/ Universal
Centrifugal / AxialFans Inline Fans	:-ABB / Kruger / Comfrei / Nuair (UK) :-Kruger / Nuair / Ostberg / Systemair/ carryaire

**NOTE: Above makes of equipment are approved subject to their meeting the specifications. The contractor however shall seek approval of specific make from Consultant/ Bank's before commencing the work. The decision of Consultant/ Bank's shall & binding on the contractor in this respect. Any other make of the equipment not specified shall be got approved by the Consultant/ Bank's.**

STATE BANK OF INDIA ,  
KHANAURI.(PB)

W-1

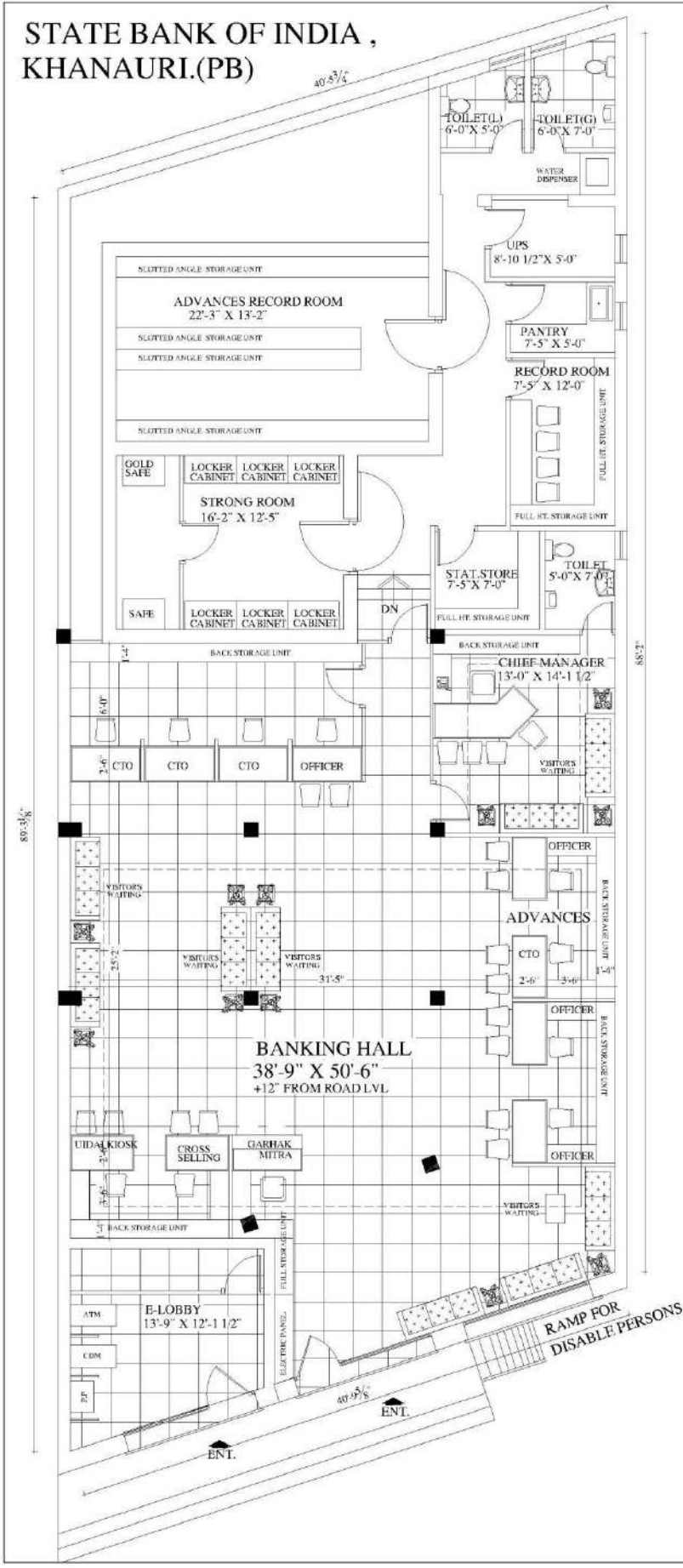

PROPOSED INTERIOR FOR STATE BANK OF INDIA KHANAURI.(PB).		
REV.	DESCRIPTION	DATE
GROUND FLOOR PLAN		JOB NO. 1198
		DRG.NO. W-1
		SCALE: 1"=1'-0"
		DATE:
 AAKAAR ASSOCIATES ARCHITECTS, ENGINEERS, INTERIOR DESIGNERS S.C.O. 28-3 SECOND FLOOR, SECTOR-38D, CHANDIGARH TEL. 0173-2601465(A) 9417395655, 9872695110(M)		NAME
DRN BY	PARDEEP	SIGN.
CHKD BY		
APRD BY	NEERAJ	

STATE BANK OF INDIA ,  
KHANAURI.(PB)

W-2

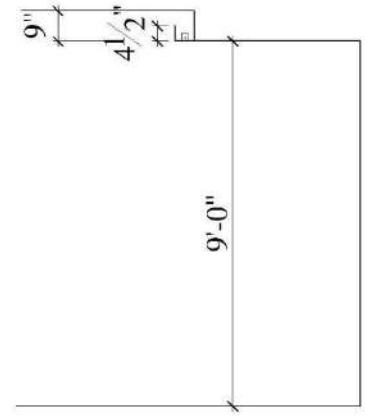
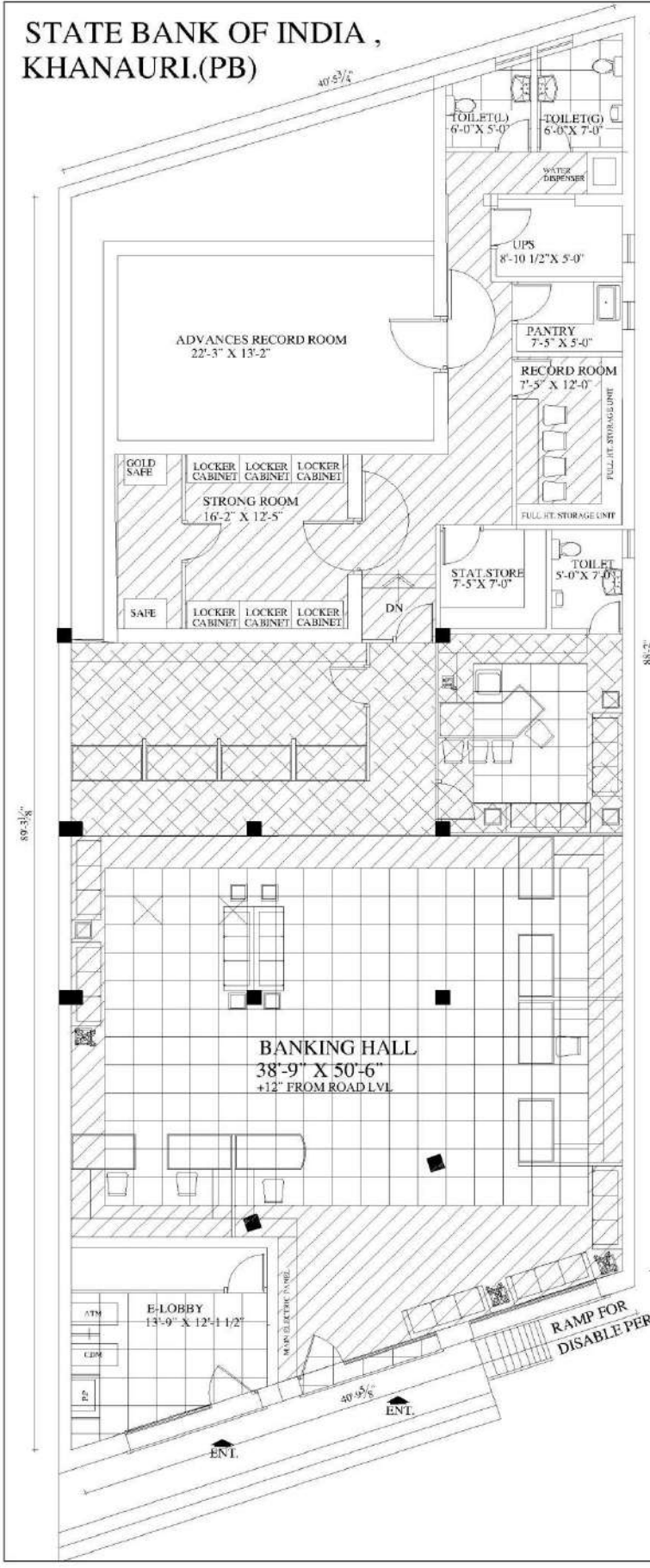

section of ceiling

LEGEND									
	GYPSUM BOARD FALSE CEILING								
	TEAK WOOD VINEAR FALSE CEILING								
	GRID CEILING (PPGI METAL PERFORATED SHEET)								
<p>PROPOSED INTERIOR FOR STATE BANK OF INDIA KHANAURI.(PB).</p>									
REV.	DESCRIPTION								
JOB NO. 1198	DRG.NO. W-2								
SCALE: 1"=1'-0" DATE:									
<p>AAKAAR ASSOCIATES ARCHITECTS, ENGINEERS, INTERIOR DESIGNERS S.C. O. 283, SECOND FLOOR, SECTOR-82, CHANDIGARH. TEL:-0173-2601485(O), 9217295655,8837895110(M)</p>	<table border="1"> <tr> <th>NAME</th> <th>SIGN.</th> </tr> <tr> <td>DRN.BY PARDEEP</td> <td></td> </tr> <tr> <td>CHKD.BY</td> <td></td> </tr> <tr> <td>APRD.BY NEERAJ</td> <td></td> </tr> </table>	NAME	SIGN.	DRN.BY PARDEEP		CHKD.BY		APRD.BY NEERAJ	
NAME	SIGN.								
DRN.BY PARDEEP									
CHKD.BY									
APRD.BY NEERAJ									

**STATE BANK OF INDIA ,  
KHANAURI.(PB)**

**W-3**

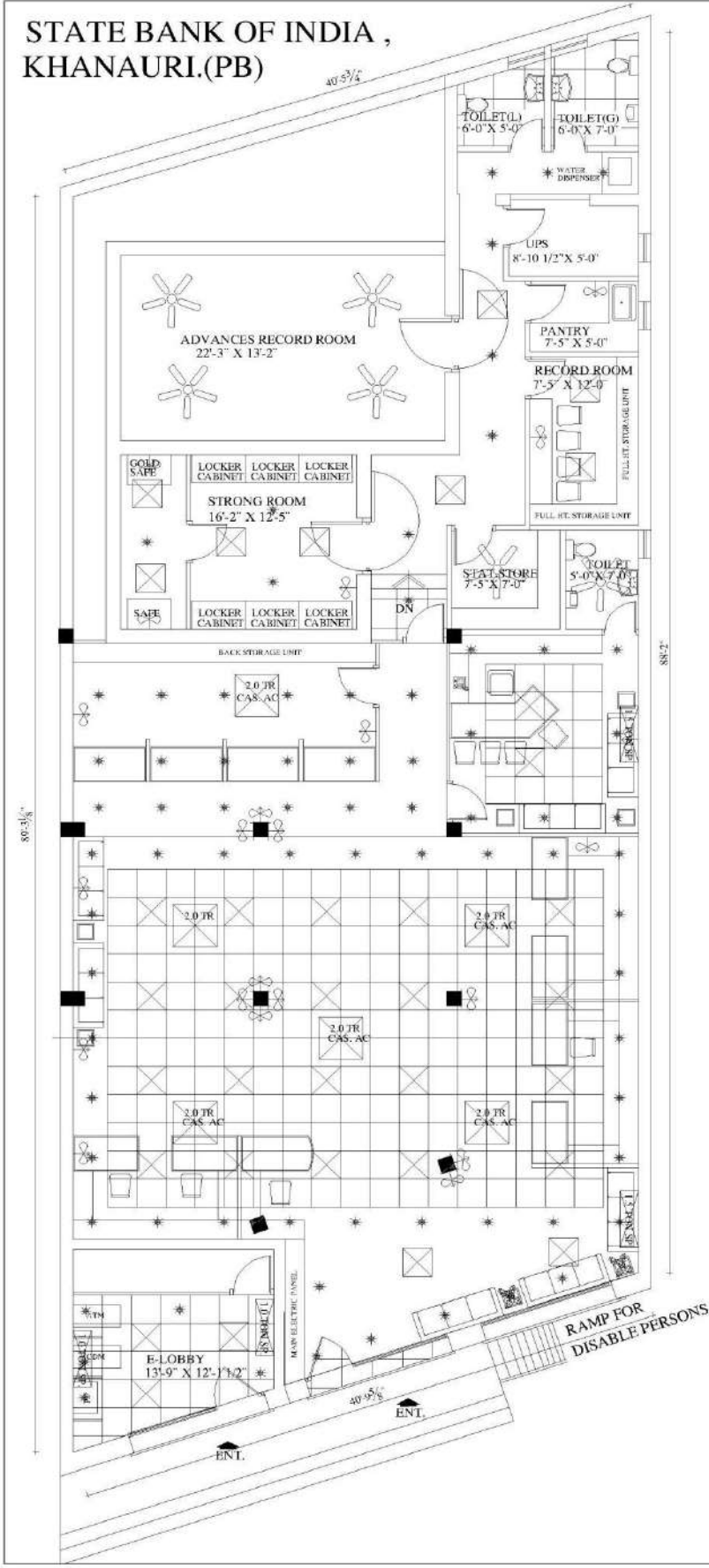

LEGEND		
	CEILING FAN	6 -NO.
	LED 36 WATTS	35-NO
	LED 15 WATTS	76-NO
	WALL FAN	22 NO
	TUBE	18-NO
	E.F	EXHAUST FAN 5-NO

PROPOSED INTERIOR FOR STATE BANK OF INDIA KHANAURI.(PB).			REV.	DESCRIPTION	DATE
GROUND FLOOR PLAN (ELECTRICAL LAYOUT )			JOB NO. 1198	DRG.NO. W-1	DATE:-
AAKAAR ASSOCIATES ARCHITECTS, ENGINEERS, INTERIOR DESIGNERS S.C.O. 38-3 SECOND FLOOR, SECTOR-38D, CHANDIGARH, TEL. 0172-2601455(2) 9617292655, 9877052110 (M)			DRN BY	NAME PARDEEP	SIGN.
			CHKD BY		
			APRD BY	NEERAJ	

STATE BANK OF INDIA ,  
KHANAURI.(PB)

W-4

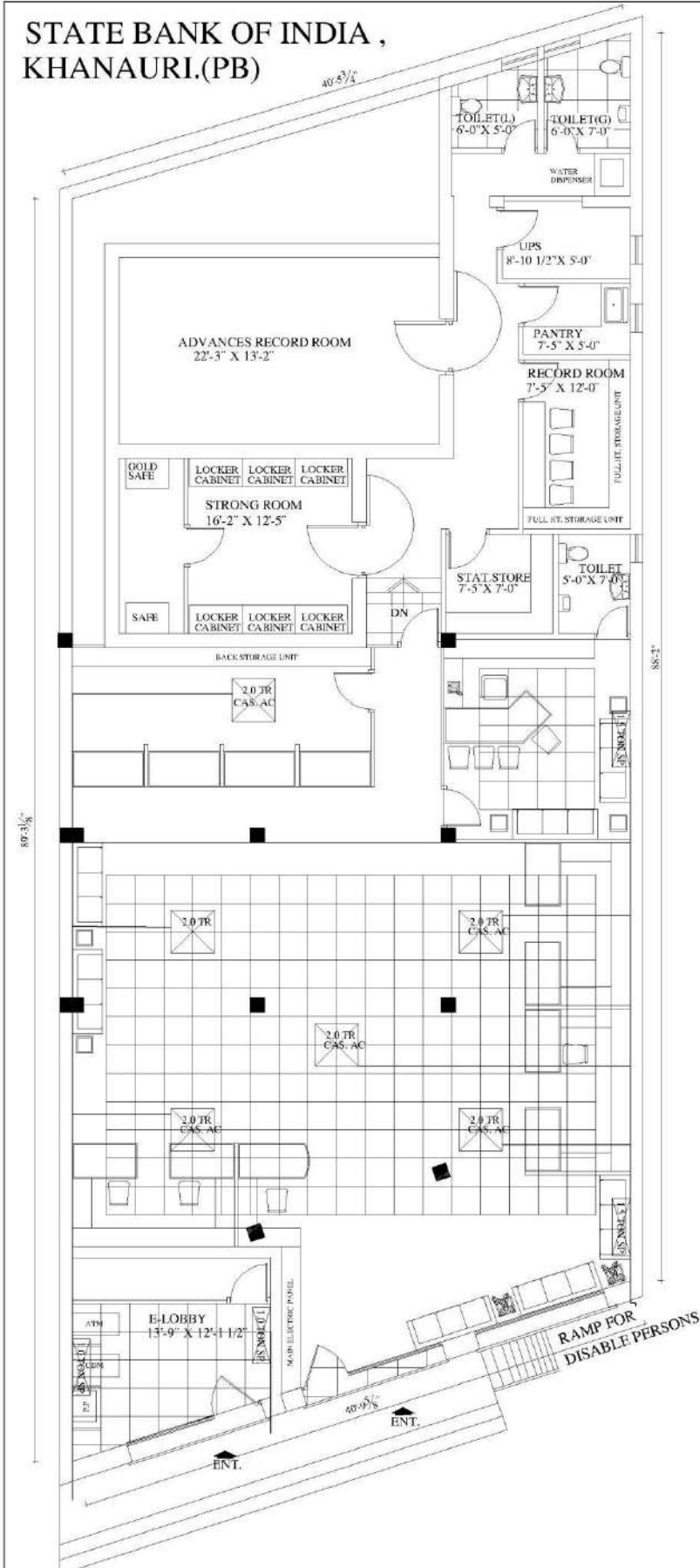

LEGEND		
	2.0 TR CASSETTE-6 NOS.	
	1.5 TON SPLIT UNIT-2 NO.	
	1.0 TON SPLIT UNIT-2 NO.	
	OUT DOOR UNIT	
	DRAIN PIPE	

PROPOSED INTERIOR FOR STATE BANK OF INDIA KHANAURI.(PB).				
REV.	DESCRIPTION	DATE		
GROUND FLOOR PLAN (A.C.LAYOUT)		JOB NO. 1198	DRG.NO.	W-4
		SCALE: 1"=1'-0"	DATE:	
AAKAAR ASSOCIATES ARCHITECTS, ENGINEERS, INTERIOR DESIGNERS S.C.D. 38-3 SECOND FLOOR SECTOR-38D, CHANDIGARH, TEL:-0173-2691495(AO) 9417205655, 987269110(M)		NAME	SIGN.	
		DRN.BY	PARDEEP	
		CHKD.BY		
APRD.BY	NEERAJ			