



ADMINISTRATIVE OFFICE, KOLHAPUR

7TH FLOOR, SHARDA CHAMBERS, SHANKARSHETH ROAD, 411042

INVITES

TENDER FOR

**INTERIOR AND FURNITURE WORKS FOR CONFERENCE ROOM AND ALLIED
WORKS AT RBO SANGLI 1ST FLOOR**

**THE FURNISHING CONTRACTORS EMPANELLED FOR MAHARASHTRA CIRCLE
UNDER THE
IE, ID, IC, CATEGORY OF (FROM – upto 25 LAKHS TO 500 LAKH)**

TENDER ID: AOKOL202604003

PART – A: TECHNICAL BID

**INTERIOR AND FURNITURE WORKS FOR CONFERENCE ROOM AND ALLIED
WORKS AT RBO SANGLI 1ST FLOOR**

TENDER SUBMITTED BY:

NAME : _____

ADDRESS : _____

DATE : _____



NOTICE INVITING TENDERS

SBI invites **INTERIOR AND FURNITURE WORKS FOR CONFERENCE ROOM AND ALLIED WORKS AT RBO SANGLI 1ST FLOOR**

The Empaneled Interior Contractors in '**Category: Interior Furnishing Works upto 25 Lakhs-** with SBI are only eligible to participate in this tender.

Contact M/s. Antares Systems Limited, Bengaluru 'Honganasu', #137/3, Bangalore Mysore Road, Opp. to Metro Pillar #P-696, Kengeri, Bengaluru – 560 060, India.

| SN | Particulars | Details |
|----|---|---|
| 1 | Name of work | Tender for <u>INTERIOR AND FURNITURE WORKS FOR CONFERENCE ROOM AND ALLIED WORKS AT RBO SANGLI 1ST FLOOR,</u> |
| 2 | Nature of Work | Civil, Interior & Carpentry Works |
| 3 | Time allowed for completion | 50 days |
| | Estimated cost | 17,24,700.00 (Rupees Seventeen Lacs twenty four thousand seven hundred only) |
| 4 | Earnest Money Deposit | Rs. 17,000.00 (Rupees Seventeen Thousand Only) by means of Demand Draft / Pay Order (Valid for a period of 90 Days from the last date of submission of the tender) from any scheduled Nationalized Bank drawn in favor of SBI and payable at Pune. |
| 5 | Security Deposit (SD) | For the successful bidder, total security deposit shall be 5% of the contract value. Out of this, 2% of the contract value will be in the form of Initial Security Deposit (ISD); which includes the EMD. Balance 3% shall be deducted from the running account bill of the work at the rate of the 10% of respective running account bill i.e. deduction from each running bill account will be 10%, till the 3% of the contract value is achieved and total of 5%. In case running bills are not paid/submitted, whole 3% of the remaining ISD will be deducted from the final bill paid. |
| 6 | Date of issue of tender documents (Technical Bid & Price Bid) from the Bank's website | 01.04.2026 to 15.04.2026 from Bank's website BANK.SBI under <Link>procurement news. |
| | Online bidding Technical Bid & Price Bid(Only SBI empaneled vendors) | From 01.04.2026 to 15.04.2026 Available at M/s e-Procurement Technologies Ltd., our Service Provider's portal https://etender.sbi/SBI/ |



| | | |
|----|--|--|
| 7 | Last date & time for submission of Technical Bid and EMD (Hard Copy) | 15.04.2026 by 03:00 PM Note: It is sole responsibility of the bidder to ensure submission of their Tender documents along with EMD by stipulated date and time at specified address failing which they will not be eligible to participate in online price bidding. |
| 8 | Address for submission of EMD and technical bid | The Deputy General Manager (B&O), Administrative Office, Kolhapur State Bank of India, 7 TH floor, Sharda Chambers, Shankarsheth Road, 411042 |
| 9 | Last date & time for submission of Online Technical bid & Price Bid | 15.04.2026 by 03:00 PM at Service Provider's portal https://etender.sbi/SBI/ |
| 10 | Date and Time of opening of offline Technical Bid and Online Technical Bid & Price Bid | 15.04.2026 by 04:00 PM |
| 11 | Defects Liability / Warranty period | 1-year from the date of installation for free replacement for any manufacturing defect (excluding damages due to natural calamities). |
| 12 | Liquidated Damages | 0.50% per week subject to max. 5% of contract amount for delay in completion of work. |
| 13 | Validity of offer | 90 days from the date of opening of Price-bid |
| 14 | Value of Interim Certificate | Rs. 7.0 Lakhs. No advance on materials / plant / machinery or mobilization advance shall be paid under any circumstances |
| 15 | Submission of Technical Bid (online and Hard Copy) | Contractors shall Download the entire Technical Bid to get acquainted with the terms and conditions and <u>shall upload compulsorily the pages numbered from 1 to 10 of the technical bid</u> without fail in the e-tendering portal after putting the signature and seal. Failing to upload as stated above, the tender will be rejected. MSME certificate will not be accepted as EMD. However, L1 Tenderer should submit the whole technical bid spirally bound securely and in serial order containing pages 1 to 45 duly signed with company seal and date to this Office within 3 days of receipt of confirmation. |

16. For any clarifications regarding Online Tendering procedure, System requirements etc. please contact Contact M/s. Antares Systems Limited, Bengaluru 'Honganasu', #137/3, Bangalore Mysore Road, Opp. to Metro Pillar #P-696, Kengeri, Bengaluru – 560 060, India..

17. The Contractor/ Vendor shall sign and stamp each page of the tender document thereby ensuring the number and sequence of all pages. Tender documents without seal and signature of the authorized tenderer are liable to be rejected.

18. No conditions other than mentioned in the tender will be considered, and if given they will have to be withdrawn before opening of the price-bid.

19. The SBI reserve their rights to accept or reject any or all the tenders, either in whole or in part without assigning any reason(s) for doing so and no claim / correspondence shall be entertained in this regard.



20. In case the date of opening of tenders is declared as a holiday, the tenders will be opened on the next working day at the same time.

Yours faithfully,

**The Deputy General Manger (B&O)
Administrative Office, Kolhapur**

INSTRUCTIONS TO THE TENDERERS

1.0 Scope of work

INTERIOR AND FURNITURE WORKS FOR CONFERENCE ROOM AND ALLIED WORKS AT RBO SANGLI 1ST FLOOR,

1.1 Site and its location

SBI RBO SANGLI, market yard Sangli

2.0 Tender documents

2.1 The work has to be carried out strictly according to the conditions stipulated in the tender consisting of the following documents and the most workmen like manner.

- Instructions to tenderers
- General conditions of Contract
- Special conditions of Contract
- Price bid

2.2 The above documents shall be taken as complementary and mutually explanatory of one another but in case of ambiguities or discrepancies, shall take precedence in the order given below:

- a. Price Bid
- b. Technical specifications
- c. Special conditions of contract
- d. General conditions of contract
- e. Instructions to Tenderers

2.3 Complete set of tender documents including relative drawings can be downloaded from the Bank's website **BANK.SBI** under <Link>procurement news as per schedule furnished in the NIT.

2.4 The tender documents are not transferable.



3.0 **Site Visit**

- 3.1 The tenderer must obtain himself on his own responsibility and his own expenses all information and data that may be required for the purpose of filling this tender document and enter into a contract for the satisfactory performance of the work. The tenderer is requested satisfy himself regarding the availability of water, power, transport and communication facilities, the character quality and quantity of the materials, labour, the law-and-order situation, climatic conditions local authorities' requirement, traffic regulations etc.

The tenderer shall be solely responsible for considering the financial effect of any or all the factors while submitting his tender.

4.0 **Earnest Money**

- 4.1 The tenderers are requested to submit the Earnest Money of **Rs. 17,000.00 (Rupees Seventeen Thousand Only)** by means of Demand Draft / Pay Order (Valid for a period of 90 Days from the last date of submission of the tender) from any Scheduled Bank drawn in favour of SBI and payable at Pune.

- 4.2 EMD in any other form other than as specified above will not be accepted. Tender not accompanied by the EMD in accordance with clause 4.1 above shall be rejected.

- 4.3 No interest will be paid on the EMD.

- 4.4 EMD of unsuccessful tenderer will be refunded within 30 days of award of Contract.

- 4.5 EMD of successful tenderer will be retained as a part of security deposit.

5.0 **Initial/ Security Deposit**

The successful tenderer will have to submit a sum equivalent to 2% of accepted tender value less EMD by means of DD drawn in favour of SBI. Payable at Pune within a period of 10 days from the date of receipt of Letter of Intent (LOI)/ Work Order from SBI.

No interest shall be paid to the amount retained by the SBI as Security Deposit.

6.0 **Signing of contract Documents**

The successful tenderer shall be bound to implement the contract by signing an agreement and conditions of contract with the respective Circles (LHOs) of SBI within 15 days from the receipt of intimation of acceptance of the tender by the SBI. However, the written acceptance of the tenders by the Bank will constitute a binding agreement between the Bank and successful tenderer whether such formal agreement is subsequently entered into or not.

7.0 **Completion Period**

Time is essence of the contract. The work should be completed in all respect accordance with the terms of contract within a period of **50 days** from the date of award of work.



8.0 **Validity of tender**

Tenders shall remain valid and open for acceptance for a period of 180 days from the date of opening price bid. If the tenderer withdraws his/her offer during the value period or makes modifications in his/her original offer which are not acceptable to Bank without prejudice to any other right or remedy the Bank shall be at liberty forfeit the EMD.

9.0 **Liquidated Damages**

The liquidated damages on account of delay shall be 0.50% of Cumulative Awarded value per week subject to a maximum of 5% of Cumulative awarded contract value or actual Invoice Value.

10.0 **Rate and prices:**

10.1 **In case of item rate tender**

10.1.1 The tenderers shall quote their rates for individual items both in words and figure. In case of discrepancy between the rate quoted in words and figures, the unit rate quantity in words will prevail. The amount of each item shall be calculated and the requisite total is given. In case of discrepancy between the unit rate and the total amount calculated from multiplication of unit rate and the quantity the unit rate quoted will govern and the amount will be corrected.

If no rate is quoted for one or more tender items, such tenders shall be treated as **Non-Responsive Tenders** and the same shall be summarily rejected.

10.1.2 The tenderers should not change the units as specified in the tender. If any unit is changed the tenders would be evaluated as per the original unit and the Contractor/ Vendor would be paid accordingly.

1.1.3 The tenderer should not change or modify or delete the description of the item. If any discrepancy is observed he should immediately bring to the knowledge of the **SBI**.

11.1.4 Each page of the BOQ shall be signed by the authorized person and cutting or overwriting shall be duly attested by him.

11.1.5 Each page shall be totaled and the grand total shall be given.

11.1.6 The rate quoted shall be firm and shall include all costs, allowances, taxes, levies during the currency of contract including authorized extension, if any, but excluding **GST**, which shall be mentioned in the bills/invoices separately, as applicable.

11.1.7 The SBI reserve their rights to accept any tenders, either in whole or in part or may entrust the work in phases or may drop the part scope of work at any stage of the project within its sole discretion without assigning any reason(s) for doing so and no claim / correspondence shall be entertained in this regard.



11.1.8 In case, it is decided by the SBI to drop one or more Items from the scope of work at any stage of the project, the Contractor/ Vendor shall not be entitled to raise any claim /compensation for such deleted scope of work. Also, the SBI may consider issuing work order for various branches/offices in phases but within a reasonable time interval and the Contractor/ Vendor shall be bound to execute the same within the stipulated time period and as per rates quoted by them in this tender without any claim for price escalation.

LETTER OF UNDERTAKING (Annexure I)

(The bidders are required to print this on their company's letter head and sign, stamp before emailing)

The Deputy General Manager (B&O),
Administrative Office, Kolhapur
State Bank of India,
7th floor, Sharda Chambers,
Shankarsheth Road,
Pune - 411042.

Dear Sir,

Having examined the drawings, specification, design and schedule of quantities relating to the works specified in the memorandum hereinafter set out and having visited and examined the site of the works specified in the said memorandum and having acquired the requisite information relating thereto as affecting the tender, I/We hereby offer to execute the works specified in the said memorandum at the rates mentioned in the attached Schedule of Quantities and in accordance in all respects with the specifications, design, drawings and instructions in writing referred to in conditions of tender, the Articles of Agreement, Special Conditions, Schedule of Quantities and Conditions of Contract and with such materials as are provided for by, and in all other respects in accordance with such conditions so far as they may be applicable.

MEMORANDUM

| | | |
|-----|---|--|
| (a) | Description of work | <u>INTERIOR AND FURNITURE WORKS FOR CONFERENCE ROOM AND ALLIED WORKS AT RBO SANGLI 1ST FLOOR</u> |
| (b) | Earnest Money | Rs. 17,000.00 (Rupees Seventeen Thousand Only) by means of Demand Draft / Pay Order (Valid for a period of 90 Days from the last date of submission of the tender) from any scheduled Nationalized Bank drawn in favour of SBI and payable in Pune. |
| (c) | Time allowed for completion of the Works from Seven day after the date of written Order or date of handing over of the site (Whichever is later) to commence the work | 50 days |



- 1) Should this tender be accepted, I/we hereby agree to abide by and fulfill the terms and provisions of the said conditions of contract annexed hereto so far as may be applicable or in default thereof to forfeit and pay to SBI, the amount mentioned in the said contract.
 - 2) I / We have deposited a sum of **Rs. 17,000.00 (Rupees Seventeen Thousand Only)** of the total tender amount as Earnest Money with the SBI which amount is not to bear any interest. Should I / We fail to execute the Contract when called upon to do so I / We do hereby agree that this sum shall be forfeited by me/us to State Bank of India.
 - 3) I/ We understand that as per terms of this tender, the SBI may consider accepting our tender in part or whole or may entrust the various work proposed in phases. We, therefore, undertake that we shall not raise any claim/ compensation in the eventuality of Bank deciding to drop any of the work from the scope of work of this tender at any stage during the contract period. Further, we also undertake to execute the work entrusted to us in phases on our approved rates and within stipulated time limit without any extra claim for price escalation as also provided for in the clause 11.1.6 "Instructions to Tenderers" of this tender.
 - 4) I/ We, hereby, also undertake that, we will not raise any claim for any escalation in the prices of any of the material during the contract/execution/completion period including authorized extended contract period, if any.
 - 5) Our Bankers are:
 - i)
 - ii)
- The names of partners of our firm are:
- i)
 - ii)

Name of the partner of the firm
Authorised to sign
Or
(Name of person having Power of
Attorney to sign the Contract.
(Certified true copy of the Power
of Attorney should be attached)
Yours faithfully,
Signature of Contractors.
Signature and addresses of Witnesses

i)



ii)

Process Compliance Statement (Annexure II)

(The bidders are required to print this on their company's letter head and sign, stamp before emailing)

To,
E-Procurement Technologies Ltd. (Auction Tiger)
B-704 Wall Street - II,
Opp. Orient Club,
Nr. Gujarat College, Ahmedabad - 380 006.
Gujarat State, India

Sub: INTERIOR AND FURNITURE WORKS FOR CONFERENCE ROOM AND ALLIED WORKS AT RBO SANGLI 1ST FLOOR.

Dear Sir,

This has reference to the Terms & Conditions for the Reverse Auction mentioned in the Tender document

This letter is to confirm that:

- 1) The undersigned is authorized representative of the company.
- 2) We have studied the Commercial Terms and the Business rules governing the Reverse Auction as mentioned in RFP of SBI as well as this document and confirm our agreement to them.
- 3) We also confirm that we have taken the training on the auction tool and have understood the functionality of the same thoroughly.
- 4) We confirm that SBI and ETL shall not be liable & responsible in any manner whatsoever for my/our failure to access & bid on the e-auction platform due to loss of internet connectivity, electricity failure, virus attack, problems with the PC, any other unforeseen circumstances etc. before or during the auction event.
- 5) **We also confirm that we have a valid digital signature certificate issued by a valid Certifying Authority.**
- 6) We also confirm that we will mail the price confirmation & break up of our quoted price as per Annexure III & Annexure IV within 24 hours of the completion of the reverse auction and the format as requested by SBI/EPTL.
- 7) We, hereby confirm that we will honor the Bids placed by us during the auction process.

With regards,



Date:

Signature with company seal

Name:

Company / Organization:

Designation within Company / Organization:

Address of Company / Organization:

Scan it and send to this Document on sujith@eptl.in

GENERAL CONDITIONS OF CONTRACT

1.0 Definitions: -

“Contract means the documents forming the tender and the acceptance there of and the formal agreement executed between SBI (client) and the Contractor/ Vendor, together with the documents referred there in including these conditions, the specifications, designs, drawings and instructions issued from time to time by the Bank and all these documents taken together shall be deemed to form one contract and shall be complementary to one another.

1.1 In the contract the following expressions shall, unless the context otherwise requires, have the meaning hereby respectively assigned to them.

1.1.1 “SBI” shall mean State Bank of India (Client) having its Corporate Centre at Madame Cama Road, Nariman Point, Mumbai- 400 021 and its representative Local Head Offices/Administrative Offices/Regional Business Offices/Branches at various places across India and includes the client’s representatives, successors and assigns.

1.1.2 ‘The Contractor/ Vendor’ shall mean the individual or firm or company undertaking the works and shall include legal personal representative of individual or composing the firm or company and the permitted assignees of individual or firms of company.

1.1.3 The expression ‘works’ or ‘work’ shall mean the permanent or temporary work description in the “Scope of work” and / or to be executed in accordance with the contract includes materials, apparatus, equipment, temporary supports, fittings and things of kinds to be provided, the obligations of the Contractor/ Vendor hereunder and work to be done by the Contractor/ Vendor under the contract.

1.1.4 Engineer’ shall mean the representative Civil / Electrical Engineer of the SBI

1.1.5 ‘Drawings’ shall mean the drawings prepared and issued by SBI or their Architects and referred to in the specifications and any modifications of such drawings as may be issued by the Engineer from time to time.

1.1.6 ‘Contract value shall mean value of the entire work as stipulated in the letter of acceptance of tender subject such additions thereto or deductions there from as may be made under the provide herein after contained.

1.1.7 Specifications’ shall mean the specifications referred to in the tender and modifications thereof as may time to time be furnished or approved by the SBI



1.1.8 "Month" means calendar month.

1.1.9 "Week" means seven consecutive days.

1.1.10 "Day" means a calendar day beginning and ending at 00 Hrs. and 24 Hrs. respectively.

1.1.11 SBI's Engineer" shall mean The Civil / Electrical Engineer in - charge of the Project, as nominated by the DGM (B&O), SBI AO Kolhapur.

2.0 **CLAUSE**

1.0 **Total Security Deposit:** The Total Security deposit comprise of

- a) Earnest Money Deposit
- b) Initial security deposit
- c) Retention Money

a) **Earnest Money Deposit -**

- The tenderer shall furnish EMD of **Rs. 17,000.00 (Rupees Seventeen Thousand Only)** in the form of Demand draft or bankers cheque drawn in favour of SBI payable at Pune, on any Scheduled Bank.
- No tender shall be considered unless the EMD is so deposited in the required form.
- No interest shall be paid on this EMD. The EMD of the unsuccessful tenderer shall be refunded soon after the decision to award the contract is taken without interest.
- The EMD shall stand absolutely forfeited if the tenderer revokes his tender at any time the period when he is required to keep his tender open acceptance by the SBI. or after it is accepted by the SBI. the Contractor/ Vendor fails to enter into a formal agreement or fails to pay the initial security deposit as stipulated or fails to commence the commence the work within the stipulated time.

b) **Initial Security Deposit (ISD)**

The amount of ISD shall be 2% of accepted value of tender (In the instant case, the cumulative contract awarded value of all the Circles put together shall be considered for the purpose) including the EMD in the form of DD/PO drawn on any scheduled Bank. They shall be deposited within 15 days from the date of acceptance of tender.

c) **Additional Security Deposit (ASD)**

Additional Security deposit (ASD)/Additional performance Guarantee (APG) shall be applicable if the bid price is below 10 % of the estimated cost put to tender. The amount of such ASD/ APG shall be the difference between 90 % of estimated cost put to tender and the quoted price.



d) **Retention Money: -**

An amount @ 5% of the bill amount will be retained by the SBI from the bills and the same will be released by the SBI against Bank guarantee for equal amount issued by any Nationalized/Scheduled Bank in the SBI's approved format valid for 1 year. The Bank guarantee shall be released only after completion of warranty period of 1-year provided no complaint is received, or the defects have been rectified by replacing the same satisfactorily.

The successful bidder may choose to submit such Bank Guarantee to the SBI soon after commencement of work to avoid deduction of retention money from the Bills.

No advance on materials / plant / machinery or mobilization advance shall be paid in any circumstances.

2.0 **Language**

The language in which the contract documents shall be drawn shall be in English.

3.0 **Errors, Omissions and discrepancies**

In case of errors, omissions and/ or disagreement between written and scaled dimensions on the drawings or between the drawings and specifications etc., the following order shall apply.

- i) Between scaled and written dimension (or description) on a drawing, the latter shall be adopted.
- ii) Between the written or shown description or dimensions in the drawings and the corresponding one in the specification the former shall be taken as correct.
- iii) Between written description of the item in the specifications and descriptions in bills of quantities of the same item, the former shall be adopted:
 - a) In case of difference between rates written in figures and words, the rate in words shall prevail.
 - b) Between the duplicate / subsequent copies of the tender, the original tender shall be taken as correct.

4.0 **Scope of Work:**

The Contractor/ Vendor shall carryout, complete and maintain the said work in every respect strictly accordance with this contract and with the directions of and to the satisfaction of the Bank to be communicated through SBI. The SBI at the direction of the Bank from time to time issue further drawings and / or written instructions, detailed directions and explanations which are hereafter collectively referred to as instructions in regard to the variation or modification of the design, quality or quantity of any work or the addition or omission or substitution work. Any discrepancy in the drawings or between BOQ and / or drawings and / or specifications should be brought to the notice of SBI immediately. The removal from the site of any material brought thereon by the



Contractor/ Vendor and any substitution of any other materials therefore the removal and / or re-executed of any work executed by him. The dismissal from the work of any person engaged thereupon.

5.0 i) **Letter of Acceptance:**

Within the validity period of the tender the SBI shall issue a letter of acceptance directly by registered post or otherwise depositing at the office of the Contractor/ Vendor as given in the tender to enter into a Contract for the execution of the work as per the terms of the tender. The letter of acceptance shall constitute a binding contract between the SBI and the Contractor/ Vendor.

ii) **Contract Agreement:**

On receipt of intimation of the acceptance of tender from the SBI the successful tenderer shall be bound to implement the contract and within ten days there of shall sign an agreement in a non-judicial stamp paper of appropriate value.

6.0 **Ownership of drawings:**

All drawings, specifications and copies thereof furnished by the SBI are the properties of the SBI. They are not to be used on other work.

7.0 **Detailed drawings and instructions:**

The SBI shall furnish with reasonable proper additional instructions by means of drawings or otherwise necessary for the execution of the work. All such drawings and instructions shall be consistent with contract documents, true developments thereof and reasonably inferable there.

The work shall be executed in conformity therewith and the Contractor/ Vendor prepare a detailed program schedule indicating therein the date of start and completion of various activities on receipt of the work order and submit the same to the SBI through the architect/consultant

8.0 **Copies of agreement**

Two copies of agreement duly signed by both the parties with the drawings shall be handed over to the Contractor/ Vendors.

9.0 **Liquidated damages:**

If the Contractor/ Vendor fails to maintain the required progress in terms of relevant clause under General Conditions of Contract (GCC) or to complete the work and clear the site including vacating their office on or before the contracted or extended date or completion, without justification in support of the cause of delay, he may be called upon without prejudice to any other right of remedy available under the law to the SBI on account of such breach to pay a liquidated damage at the rate of 0.50% of the contract value subject to a maximum of 5% of the contract value.



10.0 **Materials, Appliances and Employees**

Unless or otherwise specified the Contractor/ Vendor shall provide and pay for all materials, labour, water, power, tools, equipment transportation and any other facilities that are required for the satisfactory execution and completion of the work. Unless or otherwise specified all materials shall be new and both workmanship and materials shall be best quality. The Contractor/ Vendor shall at all times enforce strict discipline and good order among his employees and shall not employ on the work any unfit person or anyone not skilled in the work assigned to him. Workman whose work or behavior is found to be unsatisfactory by the SBI he shall be removed from the site immediately.

11.0 **Permits, Laws and Regulations:**

Permits and licenses required for the execution of the work shall be obtained by the Contractor/ Vendor at his own expenses. The Contractor/ Vendor shall give notices and comply with the regulations, laws, and ordinances rules, applicable to the contract. If the Contractor/ Vendor observes any discrepancy between the drawings and specifications, he shall promptly notify the SBI in writing. If the Contractor/ Vendor performs any act, which is against the law, rules and regulations he shall meet all the costs arising there from and shall indemnify the SBI any legal actions arising there from.

12.0 **Setting out Work:**

The Contractor/ Vendor shall set out the work and shall be responsible for the true and perfect setting out of the same and for the correctness of the positions, levels, dimensions, and alignment of all parts thereof and get it approved by the SBI before proceeding with the work. If at any time any error in this respect shall appear during the progress of the works, irrespective of the fact that the layout had been approved by SBI, the Contractor/ Vendor shall be responsible for the same and shall his own expenses rectify such error, if so, required to satisfaction of the SBI.

13.0 **Protection of works and property:**

The Contractor/ Vendor shall continuously maintain adequate protection of all his work from damage and shall protect the SBI's properties from injury or loss arising in connection with contract. He shall make good any such damage, injury, loss, except due to causes beyond his control and due to his fault or negligence.

He shall take adequate care and steps for protection of the adjacent properties. The Contractor/ Vendor shall take all precautions for safety and protections of his employees on the works and shall comply with all applicable provisions of Govt. and local bodies' safety laws and building codes to prevent accidents, or injuries to persons or property on about or adjacent to his place of work. The Contractor/ Vendor shall take insurance covers as per clause 24.0 at his own cost. The policy may be taken in joint names of the Contractor/ Vendor and the SBI and the original policy may be lodged with the SBI.



14.0 **Inspection of work:**

The SBI or their representatives shall at all reasonable times have free access to the work site and / or to the workshop, factories, or other places where materials are lying or from where they are obtained and the Contractor/ Vendor shall give every facility to the SBI and their representatives necessary for inspection and examination and test of the materials and workmanship. No person unless authorized by the SBI except the representative of Public authorities shall be allowed on the work at any time. The proposed work either during its construction stage or its completion can also be inspected by the Chief Technical Examiner's Organization a wing of Central Vigilance commission.

15.0 **Assignment and subletting**

The whole of work included in the contract shall be executed the Contractor/ Vendor and he shall not directly entrust and engage or indirectly transfer, assign or underlet the contract or any part or share thereof or interest therein without the written consent of the SBI and no undertaking shall relieve the Contractor/ Vendor from the responsibility of the Contractor/ Vendor from active & superintendence of the work during its progress.

16.0 **Quality of materials, workmanship & Test**

All materials and workmanship shall be best of the respective kinds as described in the contract/BOQ and in accordance with SBI's instructions and shall be subject from time to time to such tests as the SBI. may direct at the place of manufacture or fabrication or on the site or an approved testing laboratory. The Contractor/ Vendor shall provide such assistance, instruments, machinery, labor, and materials as are normally required for examining measuring sampling and testing any material or part of work before incorporation in the work for testing as may be selected and required by the SBI.

ii) **Samples**

All samples of adequate numbers, size, shades & pattern as per specifications shall be supplied by the Contractor/ Vendor without any extra charges. If certain items proposed to be used are of such nature that samples cannot be presented or prepared at the site detailed literature / test certificate of the same shall be provided to the satisfaction of the SBI. Before submitting the sample / literature the Contractor/ Vendor shall satisfy himself that the material / equipment for which he is submitting the sample / literature meet with the requirement of tender specifications. Only when the samples are approved in writing by SBI the Contractor/ Vendor shall proceed with the procurement and installation of the particular material / equipment. The approved samples shall be signed by SBI for identification and shall be kept on record at site office until the completion of the work for inspection / comparison at any time. SBI shall take reasonable time to approve the sample. Any delay that might occur in approving the samples for reasons of its not meeting the specifications or other discrepancies inadequacy in furnishing samples of best qualities from various manufacturers and such other aspects causing delay on the approval of the materials / equipment etc. shall be to the account of the Contractor/ Vendor.



iii) **Cost of tests**

The cost of making any test shall be borne by the Contractor/ Vendor if such test is intended by or provided for in the specification or BOQ.

17.0 **Obtaining information related to execution of work**

No claim by the Contractor/ Vendor for additional payment shall be entertained which is consequent upon failure on his part to obtain correct information as to any matter affecting the execution of the work nor any misunderstanding or the obtaining incorrect information or the failure to obtain correct information relieve him from any risks or from the entire responsibility for the fulfillment of contract.

18.0 **Contractor/ Vendor's superintendence**

The Contractor/ Vendor shall give necessary personal superintendence during the execution the works and as long, thereafter, as the SBI may consider necessary until the expiry of the defects liability period, stated here to.

19.0 **Quantities**

The bill of quantities (BOQ) unless or otherwise stated shall be deemed to have been prepared in accordance with the Indian Standard Method of Measurements and quantities. The rate quoted shall remain valid for variation of quantity against individual item to any extent.

20.0 **Works to be measured**

SBI may from time to time intimate to the Contractor/ Vendor that the work is required to be measured and the Contractor/ Vendor shall forthwith attend or send a qualified representative to assist the SBI in taking such measurements and calculation and to furnish all particulars or to give all assistance required by any of them. Such measurements shall be taken in accordance with the Mode of measurements detail in the specifications. The representative of SBI shall take measurements with the Contractor/ Vendor's representative and the measurements shall be entered in the measurement book. The Contractor/ Vendor or his authorized representative shall sign all the pages of the measurement book in which the measurements have been recorded in token of his acceptance. All the corrections shall be duly attested by both representatives. No over writings shall be made in the Measurement book should the Contractor/ Vendor not attend or neglect or omit to depute his representative to take measurements the measurements recorded by the representative of the SBI shall be final. All authorized extra work, omissions and all variations made shall be included such measurement.

21.0 **Variations**

No alteration, omission or variation ordered in writing by SBI vitiates the contract. In case the SBI thinks proper at any stage during the progress of works to make any alteration in, or additions to or omission from the works or any. alteration in the kind or quality of the materials to be used therein, the SBI shall give notice thereof in writing to



the Contractor/ Vendor shall confirm in writing within seven days of giving such oral instructions the contract shall alter to, add to, or omit from as the case may be in accordance with such notice but the Contractor/ Vendor shall not do any work extra to or make any alterations or additions to or omissions from the works or any deviation from any of the provisions of the contract, stipulations, specifications or contract drawings without previous consent in writing of the SBI and the value of such extras, alterations, additions or omissions shall in all cases be determined by the SBI and the same shall be added to or deducted from the contract value, as the case may be.

22.0 Valuation of Variations

No claim for an extra Item shall be allowed unless it shall have been executed under the authority of the SBI with the concurrence of the SBI as herein mentioned. Any such extra is herein referred to as authorized extra and shall be made in accordance with the following provisions.

- a)
 - (i) The net rates or prices in the contract shall determine the valuation of the extra work where such extra work is of similar character and executed under similar conditions as the work priced herein.
 - (ii) Rates for all items, wherever possible should be derived out of the rates given in the priced BOQ.
- b) The net prices of the original tender shall determine the value of the items omitted, provided if omissions do not vary the conditions under which any remaining items of Works are carried out, otherwise the prices for the same shall be valued under sub-Clause 'c' hereunder.
- c) Where the extra works are not of similar character and/or executed under similar conditions as aforesaid or where the omissions vary the conditions under which any remaining items or works are carried out, then the Contractor/ Vendor shall within 7 days of the receipt of the letter of acceptance inform the SBI of the rate which he intends to charge for such items of work, duly supported by analysis of the rate or rates claimed and the SBI shall fix such rate or prices as in the circumstances in its opinion are reasonable and proper, based on the market rate.
- d) Where extra work cannot be properly measured or valued the Contractor/ Vendor shall be allowed day work prices at the net rates stated in the tender, of the BOQ or, if not, so stated then in accordance with the local day work rates and wages for the district; provided that in either case, vouchers specifying the daily time (and if required by the SBI) the workman's name and materials employed be delivered for verifications to the Architect /consultant at or before the end of the week following that in which the work has been executed.
- e) It is further clarified that for all such authorized extra items where rates cannot be derived from the tender, the Contractor/ Vendor shall submit rates duly supported by rate analysis worked on the 'market rate basis for material, labour hire / running charges of equipment and wastages etc. plus 15% towards establishment charges,



Contractor/ Vendor's overheads and profit. Such items shall, not be eligible for escalation.

23.0 **Final measurement**

The measurement and valuation in respect of the contract shall be completed within one months of the virtual completion of the work.

24.0 **Virtual Completion Certificate (VCC)**

On successful completion of entire works covered by the contract to the full satisfaction of the SBI, the Contractor/ Vendor shall apply to SBI for completion certificate.

Upon the satisfactory fulfillment by the Contractor/ Vendor as stated above, the Contractor/ Vendors entitled to apply to the SBI of satisfactory completion of work. Relative to which the completion certificate has been sought, the SBI shall within fourteen (14) days of the receipt of the application for completion certificate, issue a VCC in respect of the work for which the VCC has applied.

This issuance of a VCC shall not be without prejudice to the SBI's rights and Contractor/ Vendor liabilities under the contract including the Contractor/ Vendor's liability for defects liability nor shall the issuance of VCC in respect of the works or work at any site be construction as a waiver of any right or claim of the SBI against the Contractor/ Vendor in respect of or work at the site and in respect of which the VCC has been issued.

25.0 **Insurance of works**

25.1 Without limiting his obligations and responsibilities under the contract the Contractor/ Vendor shall insure in the joint names of the SBI and the Contractor/ Vendor against all loss of damages from whatever cause arising other than the excepted risks, for which he is responsible under the terms of contract and in such a manner that the SBI. and Contractor/ Vendor are covered for the period stipulated in clause 28 of GCC and are also covered during the period of maintenance for loss or damage arising from a cause, occurring prior to the commencement of the period of maintenance and for any loss or damage occasioned by the Contractor/ Vendor in the course of any operations carried out by him for the purpose of complying with his obligations under clause.

- a) The Works for the time being executed to the estimated current Contract value thereof, or such additional sum as may be specified together with the materials for incorporation in the works at their replacement value.
- b) Such insurance shall be affected with an insurer and in terms approved by the SBI which approval shall not be unreasonably withheld and the Contractor/ Vendor shall whenever have required produce to the SBI the policy of insurance and the receipts for payment of the current premiums.

26.0 **Damage to persons and property**



The Contractor/ Vendor shall, except if and so far as the contract provides otherwise indemnify the SBI against all losses and claims in respect of injuries or damages to any person or material or physical damage to any property whatsoever which may arise out of or in consequence of the execution and maintenance of the works and against all claims proceedings, damages, costs, charges and expenses whatsoever in respect of or in relation thereto except any compensation of damages for or with respect to:

- a) The permanent use or occupation of land by or any part thereof.
- b) The right of SBI to execute the works or any part thereof on, over, under, in or through any lands.
- c) Injuries or damages to persons or properties which are unavoidable result of the execution or maintenance of the works in accordance with the contract
- d) Injuries or damage to persons or property resulting from any act or neglect of the SBI their agents, employees or other Contractor/ Vendors not being employed by the Contractor/ Vendor or for or in respect of any claims, proceedings, damages, costs, charges and expenses in respect thereof or in relation thereto or where the injury or damage was contributed to by the Contractor/ Vendor, his servants or agents such part of the compensation as may be just and equitable having regard to the extent of the responsibility of the SBI, their employees, or agents or other employees, or agents or other Contractor/ Vendors for the damage or injury.

27.0 Contractor/ Vendor to indemnify SBI

The Contractor/ Vendor shall indemnify the SBI against all claims, proceedings, damages, costs, charges and expenses in respect of the matters referred to in the provision sub-clause 25 of this clause.

28.0 Contractor/ Vendor's superintendence

The Contractor/ Vendor shall fully indemnify and keep indemnified the SBI against any action, claim, or proceeding relating to infringement or use of any patent or design or any alleged patent or design rights and shall pay any royalties which may be payable in respect of any article or part thereof included in the contract. In the event of any claim made under or action brought against SBI. in respect of such matters as aforesaid the Contractor/ Vendor shall be immediately notified thereof and the Contractor/ Vendor shall be at liberty, at his own expenses to settle any dispute or to conduct any litigation that may arise there from, provided that the Contractor/ Vendor shall not be liable to indemnify the SBI. if the infringement of the patent or design or any alleged patent or design right is the direct result of an order passed by the SBI in this behalf.

29.0 Third Party Insurance

29.1 Before commencing the execution of the work the Contractor/ Vendor but without limiting his obligations and responsibilities under clause 24.0 of GCC shall insure against his liability for any material or physical damage, loss, or injury which may occur to any property including that of SBI., or to any person, including any employee of the SBI, by



or arising out of the execution of the works or in the carrying out of the contract, otherwise than due to the matters referred to in the provision to clause 24.0 thereof.

29.2 Minimum amount of Third-Party Insurance

Such insurance shall be effected with an insurer and in terms approved by the SBI whose approval shall not be reasonably withheld and for at least the amount stated below. The Contractor/ Vendor shall, whenever required, produce to the SBI the policy or policies of insurance cover and receipts for payment of the current premiums.

The minimum insurance cover for physical property, injury, and death is Rs.5 Lakh per occurrence with the number of occurrences limited to four. After each occurrence Contractor/ Vendor will pay additional premium necessary to make insurance valid for four occurrences always.

30.0 Accident or Injury to workman:

i. The SBI shall not be liable for or in respect of any damages or compensation payable at law in respect or in consequence of any accident or injury to any workmen or other person in the employment of the Contractor/ Vendor or any sub-Contractor/ Vendor, save and except an accident or injury resulting from any act or default of the SBI or their agents, or employees. The Contractor/ Vendor shall indemnify and keep indemnified SBI against all such damages and compensation, save and except as aforesaid, and against all claims, proceedings, costs, charges and expenses whatsoever in respect thereof or in relation thereto.

ii. Insurance against accidents etc. to workmen

The Contractor/ Vendor shall insure against such liability with an insurer approved by the SBI during the whole of the time that any persons are employed by him on the works and shall, when required, produce to the architect / consultant such policy of insurance and receipt for payment of the current premium. Provided always that, in respect of any persons employed by any sub-Contractor/ Vendor the Contractor/ Vendor's obligation to insure as aforesaid under this sub-clause shall be satisfied if the sub-Contractor/ Vendor shall have insured against the liability in respect of such persons in such manner that SBI is indemnified under the policy but the Contractor shall require such sub-Vendor to produce to the SBI when such policy of insurance and the receipt for the payment of the current premium.

iii. Remedy on Contractor/ Vendor's failure to insure

If the Contractor/ Vendor fails to effect and keep in force the insurance referred to above or any other insurance which he may be required to effect under the terms of contract, then and in any such case the SBI may effect and keep in force any such insurance and pay such premium or premiums as may be necessary for that purpose and from time to time deduct the amount so paid by the SBI as aforesaid from any amount due or which may become due to the Contractor/ Vendor or recover the same as debt from the Contractor/ Vendor.



- iv. Without prejudice to the others rights of the SBI against Contractor/ Vendors. In respect of such default, the employer shall be entitled to deduct from any sums payable to the Contractor/ Vendor the amount of any damages costs, charges, and other expenses paid by the SBI and which are payable by the Contractor/ Vendors under this clause. The Contractor/ Vendor shall upon settlement by the Insurer of any claim made against the insurer pursuant to a policy taken under this clause, proceed with due diligence to rebuild or repair the works destroyed or damaged. In this event all the monies received from the Insurer in respect of such damage shall be paid to the Contractor/ Vendor and the Contractor/ Vendor shall not be entitled to any further payment in respect of the expenditure incurred for rebuilding or repairing of the materials or goods destroyed or damaged.

31.0 **Commencement of Works:**

The date of commencement of the work will be reckoned as the date of execution of agreement with Circles SBI.

32.0 **Time for completion**

Time is essence of the contract and shall be strictly observed by the Contractor/ Vendor. The entire work shall be completed within a period of **50 calendar days** from the date of commencement.

33.0 **Extension of time**

If, the work be delayed for reasons beyond the control of the Contractor/ Vendor, the Contractor/ Vendor may submit a recommendation to the SBI to grant a fair and reasonable extension of time for completion of work as per the terms of contract. If the Contractor/ Vendor need an extension of time for the completion of work or if the completion of work is likely to be delayed for any reasons beyond the due date of completion as stipulated in the contract, the Contractor/ Vendor shall apply to the SBI. in writing at least 30 Days before the expiry of the scheduled time and while applying for extension of time he shall furnish the reason in detail and his justification if any, for the delays in the prescribed format for granting extension of time. While granting extension of time the Contractor/ Vendor shall be informed the period extended time which will qualify for levy of liquidated damages. For the balance period in excess of original stipulated period and duly sanctioned extension of time by the provision of liquidated damages as stated under clause 8.0 shall become applicable. Further the contract shall remain in force even for the period beyond the due date of completion irrespective whether the extension is granted or not.

34.0 **Rate of progress**

Whole of the materials, plant and labour to be provided by the Contractor/ Vendor and the mode, manner and speed of execution and maintenance of the works are to be of a kind and conducted in a manner to the satisfaction of the SBI Should the rate of progress of the work or any part thereof be at any time be in the opinion the SBI too Slow to ensure the completion of the whole of the work the prescribed time or



extended time for completion, the SBI shall thereupon take such steps as considered necessary to expedite progress so as to complete the works by the prescribed time or extended time. Such communications from the SBI neither shall relieve the Contractor/ Vendor from fulfilling obligations under the contract nor will he be entitled to raise any claims arising out of such directions.

35.0 Work during nights and holidays

Subject to any provision to the contrary contained in the contract no permanent work shall, as herein provided, be carried on during the night or on holidays without the permission in writing of the SBI, except when the work is unavoidable or absolutely necessary for the saving of life or property or for the safety of the work in which case the Contractor/ Contractor/ Vendor shall immediately advise the SBI. However, the provisions of the clause shall not be applicable in the case of any work which becomes essential to carry by rotary or double shifts in order to achieve the progress and quality of the part of the works being technically required / continued with the prior approval of the SBI at no extra cost.

All work at night after obtaining approval from competent authorities of SBI shall be carried out without unreasonable noise and disturbance.

36.0 No compensation or restrictions of work

If at any time after acceptance of the tender, SBI shall decide to abandon or reduce the scope of work for any reason whatsoever and hence not required the whole or any part of the work to be carried out. SBI shall give notice in writing to that effect to the Contractor/ Vendor and the Contractor/ Vendor shall act accordingly in the matter. The Contractor/ Vendor shall have no claim to any payment of compensation or otherwise whatsoever on account of any profit or advantage which he might have derived from the execution of the Work fully but which he did not derive in consequence of the foreclosure of the whole or part of the work.

Provided that the Vendor shall be paid the charges on the cartage of only materials actually and bona-fide brought to the site of the work by the Contractor/ Vendor and rendered surplus as a result of the abandonment, curtailment of the work or any portion thereof and then taken back by the Vendor, provided however that the SBI shall have in such cases the option of taking over all or any such materials at their purchase price or a local current rate whichever is less.

“In case of such stores having been issued from SBI stores and returned by the Vendor to stores, credit shall be given to him at the rates not exceeding those at which were originally issued to the Vendor after taking into consideration and deduction for claims on account of any deterioration or damage while in the custody of the Contractor/ Vendor and in this respect the decision of Architect / consultant shall be final.

37.0 Suspension of work



- i) The Contractor/ Vendor shall, on receipt of the order in writing of SBI (whose decision shall be final and binding on the Contractor/ Vendor) suspend the progress of works or any part thereof for such time and in such manner as SBI may consider necessary so as not to cause any damage or injury to the work already done or endanger the safety thereof for any of following reasons:
- a) On account any default on the part of the Contractor/ Vendor, or
 - b) For proper execution of the works or part thereof for reasons other than the default the Vendor/ Contractor, or
 - c) For safety of the works or part thereof.

The Contractor / Vendor shall, during such suspension, properly protect and secure the works the extent necessary and carry out the instructions given in that behalf by the SBI.

- ii) If the suspension is ordered for reasons (b) and (c) in sub-para (i) above:

The Contractor/ Vendor shall be entitled to an extension of time equal to the period of every such suspension. No compensation whatsoever shall be paid on this account.

38.0 Action when the whole security deposit is forfeited

In any case in which under any clause or clauses of this contract, the Contractor/ Vendor shall have rendered himself liable to pay compensation amounting to the whole of his security deposit the SBI shall have the power to adopt any of the following course as they may deem best suited to the interest of the SBI:

- a) To rescind the contract (of which rescission notice in writing to the Contractor/ Vendor by SBI shall be conclusive evidence) and in which case the security, deposit of the Contractor/ Vendor shall be forfeited and be absolutely at the disposal of SBI
- b) To employ labour paid by the SBI and to supply materials to carry out the work, or part of the work, debiting the Contractor/ Vendor with the cost of the labour and materials cost of such labour and materials (as worked out by the SBI shall final and conclusive against the Contractor/ Vendor) and crediting him with the value of the work done, in all respects in the same manner and at the same manner and at the same rates as if it had been carried out by the Contractor/ Vendor under the terms of this contract certificate of SBI as to the value of work done shall be final conclusive against the Contractor/ Vendor.
- c) To measure up the work of the Contractor/ Vendor, and to take such part thereof as shall be unexecuted, out of his hands, and to give it to another Contractor/ Vendor to complete, in which case any expenses which may be incurred in excess of the sum which would have been paid to the original Contractor/ Vendor, if the whole work had been executed by him (The amount of which excess the certificates in writing of the SBI shall final and conclusive) shall be borne by original Contractor/ Vendor and may be deducted if any money due to him by SBI under the contract or otherwise, or from his security deposit or the proceeds of sale thereof, or sufficient part thereof.



In the event of any of above courses being adopted by the SBI the Contractor/ Vendor shall have no claim to compensation for any loss sustained by him by reasons of his having purchased or procured any material or entered into any engagements or make any advances on account of, or with a view to the execution of the work or the performance of the contract and in case the contract shall be rescind under the provision aforesaid, the Contractor/ Vendor shall not be entitled to recover or to be paid any sum or any work thereto for actually performed under this contract, unless, and until SBI will have certified in writing the performance of such work and the value payable in respect thereof, and he shall only be entitled to be paid the value so certified.

39.0 **Owner's right to terminate the contract**

If the Contractor/ Vendor being an individual or a firm commit any 'Act of insolvency' or shall be adjusted an insolvent or being an incorporated company shall have an order for compulsory winding up voluntarily or subject to the supervision of Govt. and of the Official Assignee of the liquidator in such acts of insolvency or winding up shall be unable within seven days after notice to him to do so, to show to the reasonable satisfaction of the SBI that he is able to carry out and fulfill the contract, and to dye security therefore if so required by the SBI

Or if the Contractor/ Vendor (whether an individual firm or incorporated Company) shall suffer execution to be issued or shall suffer any payment under this contract to be attached by or on behalf of any of the creditors of the Contractor/ Vendor.

Or shall assign or sublet this contract without the consent in writing of the SBI or shall charge or encumber this contract or any payment due to which may become due to the Contractor/ Vendor there under:

- a) has abandoned the contract; or
- b) has failed to commence the works or has without any lawful excuse under these conditions suspended the progress of the works for 14 days after receiving from the SBI written notice to proceed, or
- c) *has failed to proceed with the works with such diligence and failed to make such due progress as would enable the works to be completed within the time agreed upon, or has failed to remove the materials from the site or to pull down and replace work within seven days after written notice from the SBI that the said materials were condemned and rejected by the SBI under these conditions; or has neglected or failed persistently to observe and perform all or any of the acts matters or things by this contract to be observed and performed by the contactor for seven days after written notice shall have been given to the Contractor/ Vendor to observe or perform the same or has to the detriment of good workmanship or in defiance of the SBI to the contrary subject any part of the contract.*

Then and in any of said cases the SBI may not withstanding any previous waiver, after giving seven days' notice in writing to the Contractor/ Vendor, determine the contract,



but without thereby affecting the powers of the SBI or the obligation and liabilities of the Contractor/ Vendor the whole of which shall continue in force as fully as if the contract had not been determined and as if the works subsequently had been executed by or on behalf of the Contractor/ Vendor. And, further the SBI or their employees may enter upon and take possession of the work and all plants, tools, scaffoldings, materials, sheds, machineries lying upon the premises or on the adjoining lands or roads use the same by means of their own employees or workmen in carrying on and completing the work or by engaging any other Contractor/ Vendors or persons to the work and the Contractor/ Vendor shall not in any way interrupt or do any act, matter or thing to prevent or hinder such other Contractor/ Vendor or other persons employed for complement and finishing or using the materials and plant for the works.

When the works shall be completed or as soon thereafter as convenient to the SBI a notice in writing will be given to the Contractor/ Vendor to remove his surplus materials and plants and should the Contractor/ Vendor fail to do so within 14 days after receive thereof by him the SBI sell the same by public auction, and after due publication, and shall, adjust the amount realized by such auction. The Contractor/ Vendor shall have no right to question any of the act of the SBI incidental to the sale of the materials etc.

40.0 **Certificate of payment**

The contractor shall be entitled under the certificates to be issued by the Architect / consultant to the contractor within 10 working days from the date of certificate to payment from SBI from time to time. The SBI shall recover the statutory recovering other dues including the retention amount from the certificate of payment.

Provided always that the issue of any certificate by the Architect / consultant during progress of works or completion shall not have effect as certificate of satisfaction relieve the contractor from his liability under clause.

The Architect / consultant shall have power to withhold the certificate if the work or in part thereof is not carried out to their satisfaction.

The Architect / consultant may by any certificate make any corrections required previous certificate.

The SBI shall modify the certificate of payment as issued by the architect / consultant from time to time while making the payment

The contractor shall submit interim bills only after taking actual measurements and properly recorded in the Measurement books

The Contractor shall not submit interim bills when the approximate value of work done by him is less than **Rs. 7.00 Lakhs.**

The final bill may be submitted by contractor within a period of one month from the date of virtual completion and Architect / consultant shall issue the certificate of payment within a period of two months. The SBI shall pay the amount within a period of three months from the date of issue of certificate provided there is no dispute in respect of rates and quantities.



The contractor shall submit the interim bills in the prescribed format with all details.

After successful completion of work, the Contractor/ Vendor shall prepare separate bills for each branch/office/ATM/site and submit the branch-wise Tax Invoices/Bills along with specified 5 to 10 years Warrantee on Company Warrantee Cards / on Rs.500/- Non-Judicial Stamp paper for Supply of Furniture/waterproofing or other similar works along with a certificate/acknowledgement certifying completion of work by SBI or their authorized representative.

No advance on materials / plant / machinery or mobilization advance shall be paid in any circumstances.

The SBI shall recover the statutory recoveries viz. TDS, retention and other dues, if any, as per contractual provisions.

The SBI shall have power to withhold the payment if the work or part thereof is not carried out to their satisfaction.

41.0 A. Settlement of Disputes and Arbitration

Except where otherwise provided in the contract all questions and disputes to the meaning of the specifications, design, drawings and instructions herein before mentioned and as to the quality of workmanship or materials used on the work or as to any other question , claim, right, matter or thing whatsoever in any way arising out of or relating to the contract, designs, drawings specifications, estimates, instructions orders or these conditions or otherwise concerning the work or the execution or failure to execute the same whether arising during the progress of the work or after the cancellation, termination, completion or abandonment thereof shall be dealt with as mentioned hereinafter:

- i) If the contractor considers that he is entitled to any extra payment or compensation in respect of the works over and above the amounts admitted as payable by the Architect or in case the contractor wants to dispute the validity of any deductions or recoveries made or proposed to be made from the contract or raise any dispute, the contractor shall forthwith give notice in writing of his claim, or dispute to The DEPUTY GENERAL MANAGER (B&O), ADMINSTRATIVE OFFICE, KOLHAPUR, MAHARASHTRA CIRLE OF SBI., And endorse a copy of the same to the Architect, within 30 days from the date of disallowance thereof or the date of deduction or recovery. The said notice shall give full particulars of the claim, grounds on which it is based and detailed calculations of the amount claimed and the contractor shall not be entitled to raise any claim nor shall the SBI be in any way liable in respect of any claim by the contractor unless notice of such claim shall have been given by the contractor to **THE DEPUTY GENERAL MANAGER (B&O), ADMINSTRATIVE OFFICE, KOLHAPUR MAHARASHTRA CIRLE** in the manner and within the time as aforesaid. The Contractor shall be deemed to have waived and extinguished all his rights in respect of any claim not notified to **THE DEPUTY GENERAL MANAGER (B&O), ADMINSTRATIVE OFFICE, KOLHAPUR MAHARASHTRA CIRLE** in writing in the manner and within the time aforesaid.



B. Settlement of Disputes and Arbitration

- ii) The DGM (B&O), shall give his decision in writing on the claims notified by the receipt of the contractor may within 30 days of the receipt of the decision of The DEPUTY GENERAL MANAGER (B&O), ADMINSTRATIVE OFFICE, KOLHAPUR, MAHARASHTRA CIRCLE/ Submit his claims to the conciliating authority namely The DEPUTY GENERAL MANAGER (B&O), ADMINSTRATIVE OFFICE, KOLHAPUR, 7TH FLOOR, SHARDA CHAMBERS, SHANKARSHETH ROAD, 411042. For conciliation along with all details and copies of correspondence exchanged between him and the SBI.
- iii) If the conciliation proceedings are terminated without settlement of the disputes, the contractor shall, within a period of 30 days of termination thereof shall give a notice to the concerned Dy. General Manager & Chief Development Officer of the Maharashtra Circle for appointment of an arbitrator to adjudicate the notified claims falling which the claims of the contractor shall be deemed to have been considered absolutely barred and waived.
- iv) Except where the decision has become final, binding and conclusive in terms of the contract, all disputes or differences arising out of the notified claims of the contractor as aforesaid and all claims of the SBI shall be referred for adjudication through arbitration by the Sole Arbitrator appointed by the Dy. General Manager & Chief Development Office of the Maharashtra Circle and who will be of minimum Deputy General Manager rank. It will also be no objection to any such appointment that the Arbitrator so appointed is a SBI Officer and that he had to deal with the matters to which the Contract relates in the course of his duties as SBI, Officer. If the arbitrator so appointed is unable or unwilling to act or resigns his appointment or vacates his office due to any reason whatsoever another sole arbitrator shall be appointed in the manner aforesaid by the said Dy. General Manager & Chief Development Officer of the Maharashtra Circle. Such person shall be entitled to proceed with the reference from the stage at which it was let by his predecessor.

It is a term of this contract that the party invoking arbitration shall give a list of disputes with amounts claimed in respect of each dispute along with the notice for appointment of arbitrator.

It is also a term of this contract that no person other than a person appointed by such Chief General Manager as aforesaid should act as arbitrator.

The conciliation and arbitration shall be conducted in accordance with the provisions of the Arbitration & Conciliation Act 1996 or any or any accordance modification or reenactment thereof and the rules made there under.

It is also a term of the contract that if any fees are payable to the Arbitrator these shall be paid equally by both the parties. However, no fees will be payable to the arbitrator if he is a SBI Officer.

It is also a term of the contract that the Arbitrator shall be deemed to have entered on the reference on the date he issues notice to both the parties calling them to submit their statement of claims and counter statement of claims. The venue of the arbitration



shall be such place as may be fixed by the arbitrator in his sole discretion. The fees, if any of the arbitrators shall, if required to be paid before the award is made and published, be paid half and half by each of the parties. The Cost of the reference and of the award (including the fees, if any of the arbitrator) shall be in the discretion of the arbitrator who may direct to any by whom and in what manner, such costs or any part thereof, shall be paid and fix or settle the amount of costs to be so paid.

42.0 **Method of measurement**

Unless otherwise mentioned in the schedule of quantities or in mode of measurement, the measurement will be on the net quantities or work produced in accordance with up to date rules laid down by the Bureau of Indian Standards. In the event any dispute / disagreement the decision of the SBI shall be final and binding on the corrector.

43.0 **Maintenance of registers**

The contractor shall maintain the following registers as per the enclosed perform at site of work and should produce the same for inspection of STATE BANK OF INDIA /Architect / consultant whenever desired by them. The contractor shall also maintain the records / registers as required by the local authorities / Govt. from time to time.

- i) Register for secured advance
- ii) Register for hindrance to work
- iii) Register for running account bill
- iv) Register for labour

44.0 **Force Majeure**

44.1 Neither Contractor/ Vendor nor SBI shall be considered in default in performance of the obligations if such performance is prevented or delayed by events such as but not war, hostilities revolution, riots, civil commotion, strikes, lockout, conflagrations, epidemics, accidents, fire, storms, floods, droughts, earthquakes or ordinances or any act of or for any other cause beyond the reasonable control of the party affected or prevents or delayed. However, a notice is required to be given within 30 days from the happening of the event with complete details, to the other party to the contract.

44.2 As soon as the cause of force majeure has been removed the party whose ability perform its obligations has been affected, shall notify the other of such cessation and the actual delay incurred in such affected activity adducing necessary evidence in support thereof.

44.3 From the date of occurrence of a case of force majeure obligations of the party affected shall be suspended during the continuance of any inability so caused. With the caused itself and inability resulting there from having been removed, the agreed time completion of the respective obligations under this agreement shall stand extended a period equal to the period of delay occasioned by such events.



44.4 Should one or both parties be prevented from fulfilling the contractual obligations by state of force majeure lasting to a period of 6 months or more the two parties, shall mutually decide regarding the future execution of this agreement.

45.0 **Local laws, Acts Regulations:**

The Contractor/ Vendor shall strictly adhere to all prevailing labour laws including the contract labour (regulation and abolition act of 1970) and other safety regulations. The Contractor/ Vendors should comply with the provision of all labour legislation including the latest requirements of the Acts, laws, any other regulations that are applicable to the execution of the project.

46.0 **Accidents**

The Contractor/ Vendor shall immediately on occurrence of any accident at or about the site or in connection with the execution of the work report such accident to the architect / consultant. The Contractor/ Vendor shall also such report immediately to the competent authority whenever such report is required to be lodged by the law and take appropriate actions thereof.

47.0 The contractor's shall be bound to comply the following provision in terms of **“Restrictions imposed by the Government of India, Ministry of Finance Department of Expenditure under Rule 144 (XI) of General Financial Rules 2017 vide their order no. F. No 6/18/2019/PPD dated 23rd July 2020”** as under;

- I. Any bidder from a country which shares a land border with India will be eligible to bid in this tender ONLY if the bidder is registered with the Competent Authority (registration committee constituted by the Department for Promotion of Industry and Internal Trade).
- II. 'Bidder' (including the term 'tenderer', 'consultant' or 'service provider' in certain contexts) means any person or firm or company, including any member of a consortium or joint venture (that is an association of several persons, or firms or companies), every artificial judicial person not falling in any of the descriptions of bidders stated hereinbefore, including any agency branch or office controlled by such person, participating in a procurement process.
- III. 'Bidder from a country which shares a land border with India (such a country)' for this purpose means:
 - a. An entity incorporated, established or registered in such a country; or
 - b. A subsidiary of an entity incorporated, established or registered in such a country; or
 - c. An entity substantially controlled through entities incorporated, established or registered in such a country; or
 - d. An entity whose beneficial owner is situated in such a country; or
 - e. An Indian (or other) agent of such an entity; or
 - f. A natural person who is a citizen of such a country; or



- g. A consortium or joint venture where any member of the consortium or joint venture falls under any of the above
- IV. The beneficial owner for the purpose of (iii) above will be as under:
1. In case of A Company or Limited Liability Partnership, the beneficial owner is the natural person(s), who, whether acting alone or together, or through one or more judicial person, has a controlling interest or who exercises control through other means.
Explanation-
 - a. "Controlling ownership interest" means ownership of or entitlement to more than twenty-five percent of shares or capital or profits of the company;
 - b. "Control" shall include the right to appoint majority of the directors or to control the management or policy decisions including by virtue of their shareholding or management rights or shareholders agreements or voting agreements;
 2. In case of a partnership firm, the beneficial owner is the natural person(s) who, whether acting alone or together, or through one or more judicial person, has ownership of entitlement to more than fifteen percent of capital or profits of the partnership;
 3. In case of an unincorporated association or body of Individuals, the beneficial owner is the natural person(s), who, whether acting alone or together, or through one or more judicial person, has ownership of or entitlement to more than fifteen percent of the property or the capital or profits of such association or body of individuals;
 4. Where no natural person is identified under (1) or (2) or (3) above, the beneficial owner is the relevant natural person who holds the position of senior managing official;
 5. In case of a trust, the identification of beneficial owner(s) shall include identification of the author of the trust, the trustee, the beneficiaries with fifteen percent or more interest in the trust and any other natural person exercising ultimate effective control over the trust through a chain of control or ownership.
- V. An Agent is a person to do any act for another, or to represent another in dealings with third person.
- VI. The successful bidder shall not be allowed to sub-contract works to any contractor from a country which shares a land border with India unless such contractor is registered with the Competent Authority.
- VII. All bidders need to submit a declaration-cum-certificate (along with evidence) in this regard as per "**Annexure Q**". Failure to submit such valid declaration-cum-Certificate will make the bid liable for rejection."



ANNEXURE “Q”

Declaration-Cum- Certificate on the Letter Head of Bidder Regarding Restrictions on Procurement From Bidders From A Country Or Countries, On Grounds Of Defence In India, Or Matters Directly Related Thereto, Including National Security.

Restrictions under Rule 144 (XI) of General Financial Rules 2017 of Ministry of Finance, India order no. F. No 6/18/2019/PPD dated 23rd July 2020

I/We have read the clause regarding restrictions on procurement from a bidder of a country which shares a land border with India;

I/We, the bidder (Specify full name -----) certify that we are NOT from such a country OR, if from such a country, has been registered with Competent Authority.

I/We hereby certify that we fulfil all requirements in this regard and is eligible to be considered.

(Signature of Authorised Signatory along with Seal)

Name of authorised signatory:

Designation of Authorised signatory:

List of Evidences enclosed:

1. Copy of certificate of valid registration with the Competent Authority (Score out if not applicable)
2.
3.
4.

Date:

Place:



SPECIAL CONDITION OF CONTRACT

1. The Technical Bid should contain the following: -
 - a. Technical Bid duly signed and sealed on each page.
 - b. Banker's Cheque/Demand Draft of Earnest Money deposit.
 - c. If any, The Authorization Certificate issued by the Bank's approved Principal Manufacturer only certifying that the tenderer is an Authorized Converter/Agency of their Company and they have been specifically authorized by them (i.e. OEM) to participate in the bidding process of SBI.
 - d. If any, An undertaking from the Bank's approved OEM, in original, to the effect that in case their Authorised Agency/Converter is not able to perform contractual obligations for the project during the contract period, the Original Manufacturer shall own full responsibility to comply all contractual obligations relating the captioned work of SBI at their own (i.e. OEM's) risk cost and consequences.

The technical bid not accompanied by abovementioned any one or more documents shall be treated as non-responsive bid and the same shall be summarily disqualified. Moreover, such bidders shall not be allowed to participate in the submission of Indicative Price bidding followed by the E-reverse auction. No correspondence shall be entertained in this regard.

2. Taxes, duties, levies etc.:

The rates quoted shall be inclusive of all taxes, duties, levies, royalties, fees, cess or charges in respect of the works but excluding GST which shall be payable over and above the approved rates as per actual. Variation of taxes, duties, fees, levies etc. (excluding GST) if any, till completion of work shall be deemed to be included in the quoted rates and no extra claim on this account in any case will be entertained. If a new tax or duty or levy or cess or royalty or octroi is imposed under as statutory law during the currency of contract the same shall be borne by the Contractor/ Vendor. **GST will however be paid by the SBI as applicable.**

3. The Contractor/ Vendor shall study the schedule of items, technical specifications, drawings, design, etc. for its sufficiency considering all the regulations of local authorities and supply company and code of standard as applicable at the time of submitting the tender and shall bring to the notice of bank, addition or deletion, if any, in writing before due date of submission of tender.

4. Acceptance of tender

The SBI shall have the right to reject any or all tenders without assigning any reason. They are not to bind to accept the lowest or any tender and the tenderer or tenderers shall have no right to question the acts of the SBI However adequate transparency would be maintained by the SBI.



5. Dimensions and levels

All dimensions and levels shown on the drawings shall be verified by the contractor and the site and he will be held responsible for the accuracy and maintenance of all the dimensions and the levels. Figured dimensions are in all cases to be accepted and dimension shall be scaled. Large scale details shall take precedence over small scale drawings. In case of discrepancy the contractor shall ask for clarification from the Architect / consultant before proceeding with the work.

6. Notice of operation

The contractor shall not carry out any important operation without the Consent in with from the Architect / consultant:

7. Construction records

The contractor shall keep and provide to the Architect / consultant full and accurate records of the dimensions and positions of all new work and any other information necessary to prepare complete drawings recording details of the work as construction.

8. Safety of adjacent structures and trees

The contractor shall provide and erect to the approval of the Architect / consultant supports as may be required to protect effectively all structures and protective give to trees, which may be endangered by the execution of the works or otherwise such permanent measures as may be required by the Architect to protect the tree structures.

9. Temporary works

Before any temporary works are commenced the contractor shall submit at least in advance to the architect / consultant for approval complete drawings of all temporary works he may require for the execution of the works. The contractor shall carry out the modifications relating to strength, if required by the architect / consultant may require in accordance with the conditions of contract at his own cost the contractor shall be solely responsible for the stability and safety of all temporary works and unfinished works and for the quality of the permanent works resulting from the arrangement eventually adopted for their execution.

10. Water power and other facilities

a) The rate quoted by the contractor shall include all expenses that are required for providing all the water required for the work and the contractor shall make his own arrangements for the supply of good quality water suitable for the construction and good quality drinking water for their workers If necessary the contractor has to sink a tube well / open well and bring water by means of tankers at his own cost for the purpose The STATE BANK OF INDIA will not be liable to pay any charges in connection with the above



b) The rate quoted in the tender shall include the expenses for obtaining and maintaining power connections and shall pay for the consumption charges

c) The contractors for other trades directly appointed by the STATE BANK OF INDIA shall be entitled to take power and water connections from the temporary water and power supply obtained by the contractor. However, the concerned contractor shall make their own arrangements to draw the supply and pay directly the actual consumption charges at mutually agreed rates between them. All municipal charges for drainage and water connection for Construction purposes shall be borne by the contractor and charges payable for permanent connections, if any, shall be initially paid by the contractor and the SBI will reimburse the amount on production of receipts

d) The SBI as well as the Architect / consultant shall give all possible assistance to the Contractor's to obtain the requisite Permission from the various authorities, but the responsibility for obtaining the same in time shall be of the contractor

11. Facilities for contractor's employees

The contractor shall make his own arrangement for the housing and welfare of his staff and workmen including adequate drinking water facilities. The contractor shall also make the arrangements at his own cost for transport where necessary for his staff and workmen to and from site of work at his own cost.

12. Lighting of works

The contractor shall at all times provide adequate and approved lighting as required for the proper execution and supervision and inspection of work.

13. Firefighting arrangements

i) The contractor shall provide suitable arrangement for firefighting at his own cost. This purpose he shall provide requisite number of fire extinguishers and adequate number of buckets, some of which are to be always kept filled with sand and some with water this equipment shall be provided at suitable prominent and easily accessible place and shall be properly maintained.

ii) Any deficiency in the fire safety or unsafe conditions shall be corrected by the contractor at his own cost and, to the approval of the relevant authorities. The contractor makes the following arrangements at his own cost but not limited the following:

- a) Proper handling, storage and disposal of combustible materials and waste.
- b) Work operations which can create fire hazards.
- c) Access for fire-fighting equipment.
- d) Type, number and location of containers for the removal of surplus materials and rubbish.
- e) Type, size, number and location of fire extinguishers or other fire fighting equipment.
- f) General house keeping



14. Site order book

A site order book shall be maintained at site for the purpose of quick communication between the Architect / Consultant. Any communication relating to the work may be conveyed through records in the site order book. Such a communication from one party to the other shall be deemed to have been adequately served in terms of contract. Each site order book shall have machine numbered pages in triplicate and shall be carefully maintained and preserved by the contractor and shall be made available to the architect / consultant as and when demanded. Any instruction which the architect / consultant may like to issue to the contractor or the contractor may like to bring to the architect / consultant two copies of such instructions shall be taken from the site order book and one copy will be handed over to the party against proper acknowledgment and the second copy will be retained for their record.

15. Temporary fencing/ barricading

The contractor shall provide and maintain a suitable temporary fencing / barricading and gates at his cost to adequately enclose all boundaries of the site for the protection of the public and for the proper execution and security of the work and in accordance with the requirement of the architect / consultant and regulations of local authorities. These shall be altered, relocated and adopted from time to time as necessary and removed on completion of the work.

16. Site meetings

Site meetings will be held to review the progress and quality evaluation. The contractor shall depute a senior representative along with the site representative and other staff of approved sub-contractors and suppliers as required to the site meetings and ensure all follow up actions. Any additional review meetings shall be held if required by the architect/ consultant. -

17. Disposal of refuse

The contractor shall cart away all debris, refuse etc. arising from the work from the site and deposit the same as directed by the architect / consultant at his own cost. It is the responsibility of the contractor to obtain from the local authorities concerned to the effect that all rubbish arising out of contractor's activities at the construction site or any other off-site activities borrow pits has been properly disposed off.

18. Contractor to verify site measurement

The contractor shall check and verify all site measurements whenever requested other specialists contractors or other sub-contractors to enable them to prepare the own shop drawing and pass on the information with sufficient promptness as will in any way delay the works.

19. Displaying the name of the work



The contractor shall put up a name board of suitable size as directed by the architect/consultant indicating therein the name of the project and other details as given by the architect/consultant at his own cost and remove the same on completion of work.

20. As built drawings

- i) For the drawings issued to the contractor by the Architect / Consultant. The architect Consultant will issue two sets of drawings to the Contractor for the items for some changes have been made. From the approved drawings as instructed by the STATE BANK OF INDIA / Architect / Consultant. The contractor will make the changes made on these copies and return these copies to the architect / Consultant for their approval. In cases revision is required or the corrections are not properly marked the architect / Consultant will point out the discrepancies to the contractor. The contractor will have to incorporated these corrections and / or attend to discrepancies either on copies as directed by the architect / consultant and resubmit to him for approval. The architect / consultant will return one copy duly approved by him.

- ii) For the drawings prepared by the contractor

The contractor will modify the drawing prepared by him wherever the changes made by the STATE BANK OF INDIA / architect / consultant. And submit two copies of such modified drawings to the architect/ consultant for approval. The architect / consultant will return one copy of the approved drawing to the contractor.

21. Approved make

The contractor shall provide all materials from the list of approved makes at his own cost and also appoint the specialized agency for the waterproofing anti-termite, aluminum doors and windows and any other item as specified in the tender. The architect/consultant may approve any make / agency within the approved list as given in the tender after inspection of the sample/mock up.

22. Procurement of materials

The contractor shall make his own arrangements to procure all the required materials for the work. All wastages and losses in weight shall be to the contractors account

23. Excise duty, taxes, leviesetc.;

The contractor shall pay and be responsible for payment of all taxes, duties, levies, royalties, fees, cess or charges in respect of the works including but not limited to sales tax, tax on works contract excise duty, and octroi, payable in respect of materials, equipment plant and other things required for the contact. All of the aforesaid taxes, duties, levies, fees and charges shall be to the contractor's account and the STATE BANK OF INDIA shall not be required to pay any additional or extra amount on this account. Variation of taxes, duties, fees, levies etc. if any, till completion of work shall be deemed to be included in the quoted rates and no extra amount on this account. Variation of taxes, duties, fees, levies etc. if any, till completion of work shall be deemed to be included in the quoted rates and no extra claim on this account will in any case be entertained. If a new tax or duty or levy or



cess or royalty or octroi is imposed under as statutory law during the currency of contract the same shall be borne by the contractor.

24. Photographs:

- The Contractor shall at his own expense supply to the Architects with duplicate hard copies of large photographs not less than 25 cm. x 20 cm. (10" x 8") of the works, taken from two approved portions of each building, at intervals of not more than one months during the progress of the work or at every important stage of construction.
- In addition to above, the contractor shall be bound to submit adequate no. of site photographs along with each Running Bill for the project clearing showing major progress of work measured and claimed therein failing which the Architect/ STATE BANK OF INDIA may consider returning the Bill to the contractor and no claim for delay on this account will be entertained.



ARTICLES OF AGREEMENT

(On non-judicial Stamp Paper of Rs. 500/- or as per latest Govt. Rules)

ARTICLES OF AGREEMENT made the _____ date of _____ between STATE BANK OF INDIA, having its office at Pune hereinafter called "the Client" of the One Part and

WHEREAS the STATE BANK OF INDIA is desirous of

and has caused specifications describing the work to be done to be prepared by STATE BANK OF INDIA.

AND WHEREAS the said Drawings numbered _____ to _____ inclusive, the Specifications and the Schedule of Quantities have been signed by or on behalf of the parties hereto.

AND WHEREAS the Contractor has agreed to execute upon and subject to the Conditions set forth herein and to the Conditions set forth herein in the Special Conditions and in the Schedule of Quantities and Conditions of Contract (all of which are collectively hereinafter referred to as "the said conditions") the works shown upon the said Drawings and / or described in the said Specifications and included in the Schedule of Quantities at the respective rates therein set forth amounting to the sum as therein arrived at our such other sum as shall become payable there under (hereinafter referred to as "the said Contract Amount.)

NOW IT IS HEREBY AGREED AS FOLLOWS:

- 1) In consideration of the said Contract Amount to be paid at the times and in the manner set forth in the said Conditions, the Contractor shall upon and subject to the said Conditions execute and complete the work shown upon the said Drawings and described in the said Specifications and the priced Schedule of Quantities.
- 2) The Employer shall pay to the Contractor the said Contract Amount, or such other sum as shall become payable, at the times and in the manner specified in the said Conditions.
- 3) The term "The Architects" in the said Conditions shall mean the **STATE BANK OF INDIA**, or in the event of their ceasing to be the Architects for the purpose of this Contract for whatever reason, such other person or persons as shall be nominated for that purpose by the Employer, not being a person to whom the Contractor shall object for reasons considered to be sufficient by the Employer, PROVIDED ALWAYS that no person or persons subsequently appointed to be Architects under this Contract shall be entitled to



disregard or overrule any previous decisions or approval or direction given or expressed in writing by the outgoing Architects for the time being.

- 4) The said Conditions and Appendix thereto shall be read and construed as forming part of this Agreement, and the parties hereto shall respectively abide by submit themselves to the said Conditions and perform the Agreements on their part respectively in the said Conditions contained.
- 5) The Plans, Agreements and Documents mentioned herein shall form the basis of this Contract.
- 6) This Contract is neither a fixed lump-sum contract nor a piece work contract but a contract to carry out the work in respect of the entire building complex to be paid for according to actual measured quantities at the rates contained in the Schedule of Quantities and Rates or as provided in the said Conditions.
- 7) The Contractor shall afford every reasonable facility for the carrying out of all works relating to civil works, installation of lifts, Telephone, electrical installations, fittings air-conditioning and other ancillary works in the manner laid down in the said Conditions, and shall make good any damages done to walls, floors, etc. after the completion of his work.
- 8) The STATE BANK OF INDIA reserves to itself the right of altering the drawings and nature of the work by adding to or omitting any items of work or having portions of the same carried out without prejudice to this Contract.
- 9) Time shall be considered as the essence of this Contract and the Contractor hereby agrees to commence the work soon after the Site is handed over to him or from 14th day after the date of issue of formal work order as provided for in the said Conditions whichever is later and to complete the entire work within 50 **days** subject to nevertheless the provisions for extension of time.
- 10) All payments by the SBI under this Contract will be made only at Pune.
- 11) All disputes arising out of or in any way connected with this Agreement shall be deemed to have arisen at Pune and only the Courts in Pune shall have jurisdiction to determine the same.
- 12) That the several parts of this Contract have been read by the Contractor and fully understood by the Contractor.

IN WITNESS WHEREOF THE EMPLOYER and the Contractor have set their respective hands to these presents and two duplicates hereof the day and year first hereinabove written.



SIGNATURE CLAUSE

SIGNED AND DELIVERED by the

_____ By the
(Employer)

hand of Shri _____

(Name and Designation)

(Signature of Employer)

In the presence of :

1) Shri / Smt. _____

(Signature of Witness)

Address _____

(Witness)

SIGNED AND DELIVERED by the

_____ by the
(Contractor)

(Signature of Contractors)

in the presence of :

Shri / Smt. _____

(Signature of Witness)

Address _____

(Witness)



SAFETY CODE

1. First aid appliances including adequate supply of sterilized dressing and cotton wool shall be kept in a readily accessible place.
2. An injured person shall be taken to a public hospital without loss of time, in cases when the injury necessitates hospitalization.
3. Suitable and strong scaffolds should be provided for workmen for all works that cannot safely be done from the ground.
4. No portable single ladder shall be over 8 meters in length. The width between the side rails shall not be less than 30 cm. (clear) and the distance between two adjacent rungs shall not be more than 30 cm. When a ladder is used an extra handrail shall be engaged for holding ladder.
5. The excavated material shall not be placed within 1.5 meters of the edge of the trench half of the depth of trench whichever is more. All trenches and excavations shall be provided with necessary fencing and lighting.
6. Every opening in the floor of a building or in a working platform be provided with suitable means to prevent the fall of persons or materials by providing suitable fencing or railing whose minimum height shall be one meter.
7. No floor, roof or other part of the structure shall be so overloaded with debris or material as to render it unsafe.
8. Workers employed on mixing and handling material such as asphalt, cement, mortar, concrete and lime shall be provided with protective footwear and rubber hand gloves.
9. Those engaged in welding works shall be provided with welders' protective eye shield and gloves.
10. (i) No paint containing lead or lead products shall be used except in the form of paste readymade paint.
(ii) Suitable facemasks should be supplied for use by the workers when the paint applied in the form of spray or surface having lead paint dry rubbed and scrapped.
11. Overalls shall be supplied by the contractor to the painters and adequate facilities shall be provided to enable the working painters to wash during cessation of work.
12. Hoisting machines and tackle used in the works including their attachments anchor and supports shall be in perfect condition.
13. The ropes used in hoisting or lowering material or as a means of suspension shall be durable quality and adequate strength and free from defects.



(A) Contact Information

| M/s. Antares Systems Limited | State Bank of India |
|---|--|
| <p>'Honganasu', #137/3, Bangalore Mysore Road, Opp. to Metro Pillar #P- 696, Kengeri, Bengaluru – 560 060, India</p> | <p>The DGM (B&O), Administrative Office, Kolhapur 7th floor, Sharda Chambers, Shankarsheth Road, Pune 411042</p> <p>Officer Name: Aditya Deshpande Designation: Assistant Manager (Civil) Department: Premises & Estate, AO Kolhapur Contact No: 7000190836 E-mail :aditya.deshpande1@sbi.co.in</p> |
| <p>Vendor Help Desk: 9073677150 / 9073677151 / 9073677152 / 9674758723 / 9674758726 / 9674758506 / 9686449042 / 9708966660 / 9044314492 / 8951944383 / 9771414548 / 9708966664 / 9731967722 / 9606921010</p> <p>Mr. Kushal Bose Contact No : 9674758719 E-mail : helpdesk857@etenderwizard.com</p> | |



INDEX
PROFORMAS OF VARIOUS TESTS

| TABLE NO. | DESCRIPTION | PAGE NO. |
|------------------|---|-----------------|
| 1. | Record of Cement/Received/Used/Balance. | |
| 2. | Proforma of Paint/Lead/CICO Register. | |
| 3. | Bank for Reinforcement Bars Received. | |
| 4. | Proforma for Register of Material of Site Account. | |
| 5. | Proforma for Account of Secured Advance Register. | |
| 6. | Proforma for Bulkage Test of Sand Register. | |
| 7. | Proforma for Silt Test Register. | |
| 8. | Proforma for Sieve Analysis of Fine Aggregate Register. | |
| 9. | Proforma for Sieve Analysis of Coarse Aggregate Register. | |
| 10. | Proforma for Slump Test Register. | |
| 11. | Proforma of Cube Test Register. | |
| 12. | Proforma for Hindrance to Work. | |
| 13. | Proforma for Running A/c. Bill. | |
| 14. | Account of Secured Advance if Admissible on Materials Held at Site by the Contractors | |
| 15. | Memorandum for Payment. | |



TABLE-I

RECORD OF CEMENT RECEIVED / USED / BALANCE

| S. No. | Cement in stock Bags | Cement received (Bags) | Total Cement received (Bags) | Source from which received | Description of work where cement is used | Number of cement bags consumed | Balance in stock | Signature of Contractors Bank / Engineer |
|--------|----------------------|------------------------|------------------------------|----------------------------|--|--------------------------------|------------------|--|
| 1 | 2 | 3 | 4 | 5 | 6 | 7 | 8 | 9 |
| | | | | | | | | |



TABLE-II

RECORD OF PAINT / LEAD / CICO REGISTER

Name of work :

Name of the Contractor :

Agreement No. :

| Date of Receipt | Source Receipt with Ref. To S.O./In dent | Qty. Received | Progressive Total | Item of work for which issued with approx qty. work done in case of paint only | Date of issues | Quantity issued | Qty. returned at the end of the day | Total issued | Delay Balance at hand | Contractors initials | Site Engineers initials | Signature of Banks/ Architect |
|-----------------|--|---------------|-------------------|--|----------------|-----------------|-------------------------------------|--------------|-----------------------|----------------------|-------------------------|-------------------------------|
| 1 | 2 | 3 | 4 | 5 | 6 | 7 | 8 | 9 | 10 | 11 | 12 | 13 |
| | | | | | | | | | | | | |

Register for bitumen should be maintained. The format will be similar to that for cement.



TABLE-III

BANK FOR REINFORCEMENT BARS RECEIVED

| Truck No. | Challan No. | Name of Supplier | Binding Wire | 6mm dia | 8mm dia | 12m m dia | 16m m dia | 20m m dia | 25m m dia | Total Received |
|-----------|-------------|------------------|--------------|---------|---------|-----------|-----------|-----------|-----------|----------------|
| 1 | 2 | 3 | 4 | 5 | 6 | 7 | 8 | 9 | 10 | 11 |
| | | | | | | | | | | |

Number of diameters given is only illustrative. Open more columns for other diameters wherever needed.



TABLE-IV

PROFORMA FOR REGISTER OF MATERIAL AT SITE ACCOUNT

Name of Work : Name of Article :
Name of Contractor : Estimated Requirement :
Agreement No. : Issue Rate :

| Date of Receipt | Received from/Issued to (with Ret. to So/Indent) | Receipt | Issue | Balance | Initials of Contractor | Initial of Bank's/Architect's representative | Remark |
|-----------------|--|---------|-------|---------|------------------------|--|--------|
| 1 | 2 | 3 | 4 | 5 | 6 | 7 | 8 |
| | | | | | | | |



TABLE-V

PROFORMA FOR REGISTER OF MATERIAL AT SITE ACCOUNT

Name of Work :

Name of Contractor :

Agreement No. :

| Descript ion of Material | Qty. outstanding from previous Bill | Deduct Qty. utilised in works measured since previous bill | Qty. outstanding & Qty. brought to site since previous bill | Signature of Site Engineer | Signature of Contracto r | Initial of Bank's/ Architect's representative | Remark |
|--------------------------------|--|---|---|----------------------------------|-----------------------------------|---|--------|
| 1 | 2 | 3 | 4 | 5 | 6 | 7 | 8 |
| | | | | | | | |



TABLE-VI

PROFORMA FOR BULKAGE TEST OF SAND REGISTER

| Sr. .No. | Date of Test | Volume of dust sand in Cylinder inundated & stirred | Volume inundated Sand in Cylinder | Percentage of Bulkage | Signature of Site Engineer | Signature of Contractor | Initial of Bank's Architect's representative (Periodical) |
|-------------|-----------------|---|---|--------------------------|----------------------------------|-------------------------------|--|
| 1 | 2 | 3 | 4 | 5 | 6 | 7 | 8 |
| | | | | | | | |



TABLE-VII

PROFORMA OF SILT TEST REGISTER

| Sr. No | Date of Test | Height of Sand in Cylinder inundated & stirred | Height of Silt | Max percentage of silt as specified | Percentage of silt obtained | Signature of Site Engineer | Signature of Contractor | Initial of Bank's / Representative (Periodical) |
|--------|--------------|--|----------------|-------------------------------------|-----------------------------|----------------------------|-------------------------|---|
| 1 | 2 | 3 | 4 | 5 | 6 | 7 | 8 | 9 |
| | | | | | | | | |



TABLE-VIII

PROFORMA SIEVE ANALYSIS OF FINE AGGREGATE REGISTER

| Sr. No | Date of Test | Wt. of Material to be tested | Sieve as per I.S. designation | Wt. of Sand retained in sieve | %a retained in each sieve successively | Cumulative % retained in each sieve | F.M. | Signature of Site Engineer | Signature of Contractor | Signature of Banks/ Architect's representative & Remarks (Periodical) |
|--------|--------------|------------------------------|-------------------------------|-------------------------------|--|-------------------------------------|------|----------------------------|-------------------------|---|
| | | | | | | | | | | |



TABLE-IX

PROFORMA OF SIEVE ANALYSIS OF COARSE AGGREGATE REGISTER

| S. No. | Date of Testing | Wt. of Material to be tested | Nominal size of Aggregate | I.S. Sieve designation | Standard passing for graded aggregate. of nominal size | Test Result | Obtained passing | Signature of Site Engineer | Signature of Contractor | Signature of Banks/ Architect's representative & Remarks (Periodical) |
|--------|-----------------|------------------------------|---------------------------|------------------------|--|-------------|------------------|----------------------------|-------------------------|---|
| 1 | 2 | 3 | 4 | 5 | 6 | 7 | 8 | 9 | 10 | 11 |
| | | | | | | | | | | |



TABLE-X

PROFORMA FOR SLUMP TEST REGISTER

| Sr. No | Date of Testing | Type of work for which slump taken | Specified slump | | Slump Obtained | | Signature of Site Engineer | Signature of Contractor | Signature of Banks/ Architect's representative & Remarks (Periodical) |
|--------|-----------------|------------------------------------|-------------------------|-----------------------------|-------------------------|-----------------------------|----------------------------|-------------------------|---|
| | | | When Vibrators are used | When Vibrators are not used | When Vibrators are used | When Vibrators are not used | | | |
| 1 | 2 | 3 | 4 | 5 | 6 | 7 | 8 | 9 | 10 |
| | | | | | | | | | |



TABLE-XI

PROFORMA OF CUBE TEST REGISTER

| Date of taking Cube + Lime | Sample No. | No. of Cubes taken | Specific marking of Cubes | Proportion of mixture | Description of work carried out | Signature of Engineer taking sample | Signature of Contractor | 7/28 Days Testing | | | | Permissible Compressive strength of Concrete / 28 Days / 7 days | | Remarks on Test Report and No. | Remarks of Banks/ Architects representative Periodicals |
|----------------------------|------------|--------------------|---------------------------|-----------------------|---------------------------------|-------------------------------------|-------------------------|-------------------|-----------------------|---------------------------|-------------------------------|---|---------|--------------------------------|---|
| | | | | | | | | Date of Test | Test Result Kg/ Sq.cm | Av. Strength Kg. / Sq.cm. | Standard strength Kg / Sq.cm. | 7 Days | 28 Days | | |
| 1 | 2 | 3 | 4 | 5 | 6 | 7 | 8 | 9 | 10 | 11 | 12 | 13 | | 14 | 15 |
| | | | | | | | | | | | | | | | |



TABLE-XII

PROFORMA FOR HINDRANCE TO WORK

Name of Work : Date of Start of work :
Name of Contractor : Period of Completion :
Agreement No. : Dt. of Completion of work :

| S.No. | Nature of Hindrance | Date of Occurrence of Hindrance | Date of which Hindrance was removed | Period of which Hindrance existed | Signature of Site Engineer | Signature of Bank / Architects Representative |
|-------|---------------------|---------------------------------|-------------------------------------|-----------------------------------|----------------------------|---|
| 1 | 2 | 3 | 4 | 5 | 6 | 7 |
| | | | | | | |

PROFORMA FOR RUNNING A/C BILL

- i. Name of Contractor / Agency :
- ii. Name of Work :
- iii. Sl.No. of this Bill :
- iv. No. & Date of previous Bill :
- v. Reference to Agreement No. :
- vi. Date of Written order to commence :
- vii. Date of Completion as per Agreement :

| S.No. | Item Description | Unit | Rate (Rs.) | As per Tender | |
|-------|------------------|------|------------|---------------|--------------|
| | | | | Quantity | Amount (Rs.) |
| 1 | 2 | 3 | 4 | 5 | |
| | | | | | |
| | | | | | |
| | | | | | |

| Upto Previous R.A. Bill | | Up Date (Gross | | Present Bill | | Remarks |
|-------------------------|--------------|----------------|--------------|--------------|--------------|---------|
| Quantity | Amount (Rs.) | Quantity | Amount (Rs.) | Quantity | Amount (Rs.) | |
| 6 | | 7 | | 8 | | 9 |
| | | | | | | |
| | | | | | | |

- Note: 1. If part rate is allowed for any items, it should be indicated with reasons for allowing such a rate.
2. If ad-hoc payment is made, it should be mentioned specifically.

Net Value since previous bill

CERTIFICATE

The measurements on the basis of which the above entries for the Running Bill No. ----- were made have been taken jointly on ----- and are recorded at pages ----- to ----- of measurement book No. -----.



Signature and
date of Contractor

Signature and
date of Architects
Representative (Seal)

Signature and
date of Site Engineer

The work recorded in the above-mentioned measurements has been done at the site satisfactorily as per tender drawings, conditions and specifications.

Architect

Signature and
date of Site Engineer



TABLE - XIV

**ACCOUNT OF SECURED ADVANCE, IF ADMISSIBLE ON
MATERIALS HELD AT SITE BY THE CONTRACTOR**

| S.No. | Item | Quantity | Unit | Amount | Remarks |
|-------|------|----------|------|--------|---------|
| 1 | 2 | 3 | 4 | 5 | 6 |
| | | | | | |

Total value of materials at Site.

Secured Advance @ ----- of above value - B

CERTIFIED:

- (i) That the materials mentioned above have actually been brought by the Contractor to the site of the work and on advance on any quantity of any of this item is outstanding on their security.
- (ii) That the materials (are of imperishable nature) and are all required by the Contractor for use in the work in connection with the items for which rates of finished work have been agreed upon.

Dated Signature of
Site Engineer
Preparing the bill
Rank -----

Date signature of
Banks Architects-----
(Name of the Architects)

Dated Signature of
the Contractor

SIGNATURE OF CONTRACTOR &
SEAL OF FIRM

MEMORANDUM FOR PAYMENT

R/A BILL NO.

| | | |
|----|---|-----------|
| 1. | Total value of work done since previous bill (A) | Rs. ----- |
| 2. | Total amount of secured advance due since Previous Bill (B) | Rs. ----- |
| 3. | Total amount due since Previous Bill (C) (A+B) | Rs. ----- |
| 4. | PVA on account of declaration in price of Steel, Cement and other materials and labour as detailed in separate statements enclosed. | Rs. ----- |
| 5. | Total amount due to the Contractor | Rs. ----- |

OBJECTIONS:

| | | |
|------|---|-----------|
| i) | Secured Advance paid in the previous R/A | Rs. ----- |
| ii) | Retention money on value of works as per accepted tenders upto date amount Rs. | Rs. ----- |
| | Less already recovered | Rs. ----- |
| | Balance to be recovered | Rs. ----- |
| iii) | Mobilization Advance, if any | |
| (a) | Outstanding amount (principal + interest) as on date | Rs. ----- |
| (b) | To be recovered in this bill | Rs. ----- |
| iii. | Any other Departmental materials cost to be recovered as per contract, if any | Rs. ----- |
| iv. | Any other Departmental service charges to be recovered if any, as per contract (water, power etc.) enclose statement. | Rs. ----- |
| | Total Deduction as per contract (F) | Rs. ----- |

SIGNATURE OF CONTRACTOR &
SEAL OF FIRM



Adjustments, if any ----- Rs. -----
 Amount less received by Contractor in
 ----- R/A Bill (as per statement of
 Contractor)

P.V.A. Rs. -----

Total amount payable as per contract Rs. -----
 (E+F+G)

(Rupees ----- in
 words)

The bill amount to Rs. ----- (both figures and words) has been scrutinized by us after due checking of the measurements of work as required and is recommended for payment.

Date: -----

 Signature of Architect
 with Seal

The bill amount to Rs. ----- certified by Consultants has been scrutinized by me after due test checking of measurements of works as required and is recommended for payment for an amount of Rs.....

Date : -----

Signature of Owners
 Engineer

STATUTORY DEDUCTION:

- i) Total Amount due (E) Rs. -----
- ii) Less I.T. Payable Rs. -----
- iii) Less S.T. Payable Rs. -----
- Net Payable Rs. -----

This figures given in the Memorandum for payable has been verified and bill passed for payment ----- (in words and figures)

Date: -----

 Signature of the Regional Manager.



LIST OF MATERIALS OF APPROVED BRAND AND THEIR MANUFACTURERS

| | | |
|----|--|---|
| 1 | VITRIFIED Tiles | Kajaria/Somany/ H.R. Johnson/ Nitco |
| 2 | Ceramic wall Tiles | Kajaria/Somany/ H.R. Johnson/ Nitco |
| 3 | Ceramic floor Tiles (antiskid) | Kajaria/Somany/ H.R. Johnson/ Nitco |
| 4 | False Flooring | Unifloor /Flexi Access Floor/Armstrong/ |
| 5 | Wooden Laminated Flooring | Pergo/Tiles/ Tesla/ Armstrong/Vista. |
| 6 | GI SUPPORT SYSTEM FOR PLAINFALSE CEILING. | GYPSTEEL ULTRA / US BORAL |
| 7 | GI DRY WALL PARTITION SYSTEM. | GYPSTEEL / US BORAL / FRAMEWORK / RONDO / BMS. |
| 8 | GYP SUM / PLASTER BOARDS | GYPBOARD / LAGYP |
| 9 | GI SUPPORT SYSTEM FOR GRIDCEILING | ARMSTRONG / GYPSTEEL ULTRA / US BORAL |
| 10 | Aluminum Fittings | Jindal/Hindalco/MAAN |
| 11 | Aluminum Extrusion Sections | Jindal/Hindalco/MAAN |
| 12 | BWR/ MR PLYWOOD | Century/Green/ Samrat/Archid |
| 13 | Laminates (1.00mm thk.) | Royale touch / Century / Green lam |
| 14 | Veneer | Century / Durian / Green |
| 15 | Drawer Sliding Fittings | Godrej/ Hettich/Heffle/EBCO |
| 16 | Floor Spring / Door Closure | Godrej /Hardwyn /Hyper/DOORSET / STERLING/DORMA / OZONE |
| 17 | Triple Computer monitor mount/stand arm | Vivo/ Dell/ HP |
| 18 | Flush Door | Century/ Anchor/Samrat/ Green |
| 19 | Texturized Interior Paint | Dulux/ Berger/Asian/ Nerolac |
| 20 | Readymade Computer Drawer | Ebco/ Hettich/ Blum |
| 21 | Paints | Asian/ Nerolac/ Berger/Dulux |
| a) | Cement paint | Snowcem/ Surfacedm/ Durocem. |
| b) | Synthetic Enamel Paint | Asian/ Nerolac / Berger/ Dulux. |
| c) | Acrylic Emulsion Paint (Interior and Exterior) | Asian/ Nerolac / Berger / Dulux |
| 22 | Glazing | SAINT GOBAIN / GUJRAT GUARDIAN / PILLINKTON / TRIVENI/ MODIFLOAT / ASAHIFLOAT |
| 23 | Cement | Grade 43/53 of Ultra tech, A.C.C., Ambuja. |
| 24 | Fibre Mineral False Ceiling | Armstrong /Indian Gypsum Board/Gyproc. |
| 25 | ACP Panels | Aluco bond/ ALU Décor/ Alstrong/Alstone |
| 26 | Acrylic Sheets | Sanmati Acrylics/Acrylic Sheet India/ Acry Plus |
| 27 | Vertical/Roller blinds | Vista/MAC/DACK |

SIGNATURE OF CONTRACTOR&
SEAL OF FIRM



| | | |
|----|------------------------|---|
| | | |
| 28 | Block Boards | Century ply/Green Ply/Kit Ply/VI PLY |
| 29 | ADHESIVES. | FEVICOL SH / ARALDITE |
| 30 | ACRYLIC SOLID SURFACE. | LG Hausys, HI - MACS / DUPONT - MONTELLI / MERINO -HANEX / LOTTE - STARON |

- NB. 1) The contractor should obtain prior approval from Employer / Consultants before placing order for any specific materials. Employer may / delete any of the makes or brands out of the above list.
- 2). All materials should conform to relevant standards and codes of BIS.
- 3) Materials with I.S.I. mark shall be used duly approved by the STATE BANK OF INDIA Engineer / Architect.

Note: - If any material is found to be not up to the mark, the contractor will have to produce original bills/certificate from the manufacturer or his authorized Distributor for authenticity and genuineness of the material for consideration and as per make approved by the STATE BANK OF INDIA. The same will not be considered for payment.



MODE OF MEASUREMENT

1. Unless otherwise stated, all pipes shall be measured net, length as laid and measured overall fittings, such as bends, junctions, etc., and given in running meters. The length shall be taken along the center line of the pipes and fittings.
1. False Ceiling shall be measured in Plan area (length x width) only; irrespective of design in vertical patta, coves, dome etc.
2. Storage/ Almirah/ Wardobes etc shall be measured in elevation area (width x height) only; irrespective of depth from 450 mm to 600 mm.
4. Length of fittings viz, taps, valves, traps etc., which are paid under appropriate items shall not be re-measured under linear measurements as enumerated above.
5. Soil waste and vent pipes shall be measured along the center line of the stack including the connecting bends/tees to W.C. Pan, Nahani trap, etc. and shall be paid as enumerated above.
6. W.C. Pans, Lavatory basins, Sinks, Drain boards, Urinals, Mirrors, Glass shelf Toilet paper Holder, shall be measured by number and shall include all accessories as enumerated in detail specification under each item.
7. Unless otherwise specified, all types of taps, valves, etc., shall be measured by number and paid separately.
8. Manholes, inspection Chambers, Gully traps, etc. shall be constructed according to detail specification and measured by number and paid separately. The depth of Manhole shall mean the vertical distance from the top of the Manhole cover to the outgoing invert of the main drain channel.
9. Water meter shall include Y strainer and other appurtenances required by the local bodies and shall include brick masonry chamber, etc., as per detailed specifications and item shall be measured by number and paid for accordingly or as per schedule of quantity.



PREAMBLE TO SCHEDULE OF QUANTITIES

Note: While quoting rates for each item of work, the contractor shall include for the following irrespective whether it has been mentioned or not in the description of the item without any extra claim / payment.

1. All unexposed surfaces of timber (any variety) used shall be treated with necessary coats of wood preservative.
2. All exposed surfaces of timber (any variety) shall also have necessary coat of wood primer / putty and paint / polish as per description in the item.
3. Before making bulk quantities, the contractor shall make each of the item as sample and get it approved in writing from the consultant's minor modification if and as suggested by the consultant the same shall have to be incorporated without any extra cost.
4. All exposed edges of ply board shall be fixed with cedar / teak wood lipping.
5. All fabrics / leatherite to be used shall cost Rs. 300/ - per meter unless otherwise specified in the item.
Difference in cost for approved sample shall be adjusted accordingly.
6. For furniture item where required whether mentioned or not shall be include providing fixing of Brass / Power coated handles /knobs multipurpose locks, mini tower bolts, ball catchers, hinges, screws and sliding rails etc.
7. Back of all storage, cabinets, and consoles shall be in 6mm commercial ply only.
8. Thickness of laminates to be used shall be 1 mm except where specified.
9. Ant termite treatment is to provide for all wood / board /ply used in the storage.

SIGNATURE OF CONTRACTOR &
SEAL OF FIRM

Drawing of different items:-

FURNITURE DETAIL
BRANCH HEAD TABLE
PERSONEL BANKING & SME

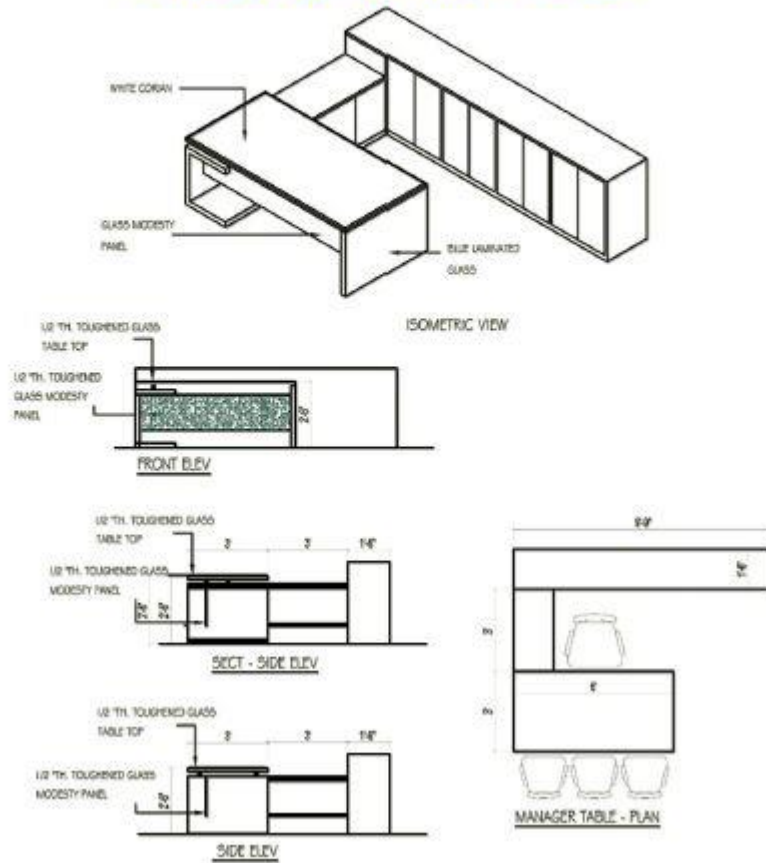

FURNITURE DETAIL
OFFICER TABLE PERSONEL
PB & SME



FRONT ELEVATION



SIDE ELEVATION AT Z

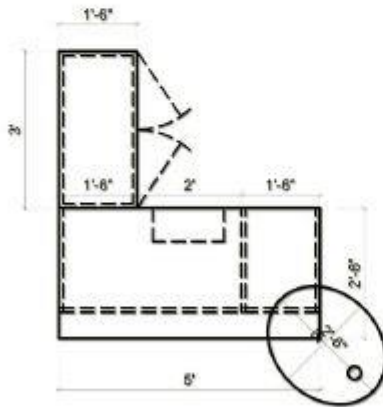

OFFICER TABLE - PLAN

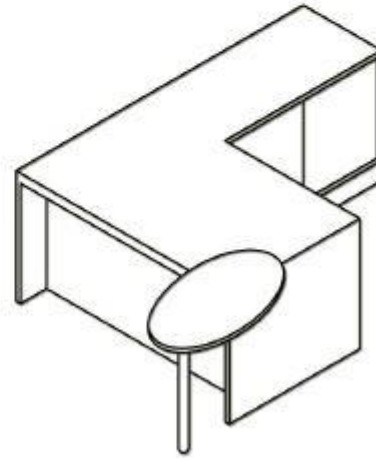

ISOMETRIC VIEW

FURNITURE DETAIL

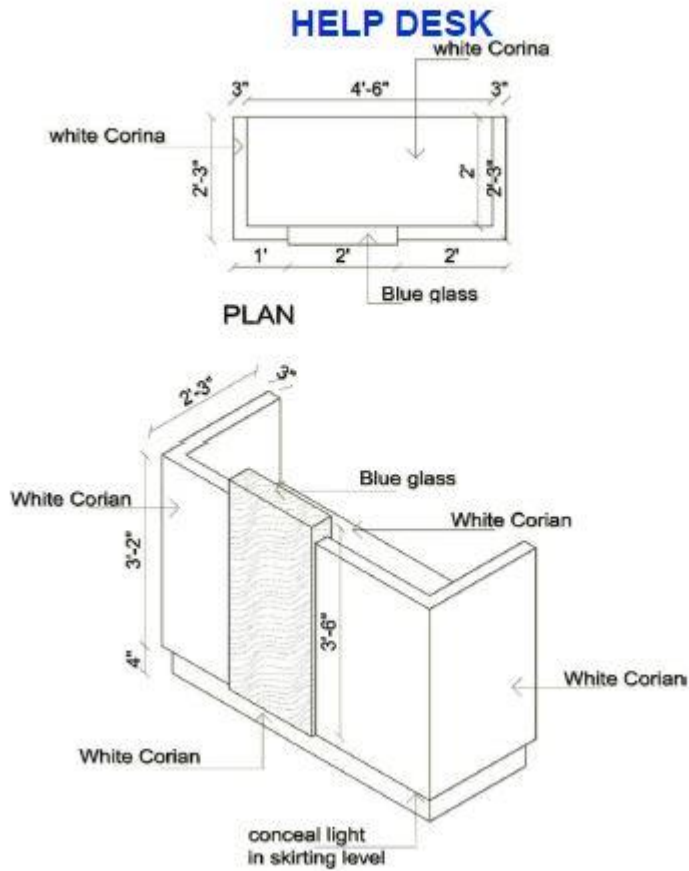

EXTERNAL FACADE

BLUE ACP



WHITE ACP



FURNITURE DETAIL

OFFICER TABLE

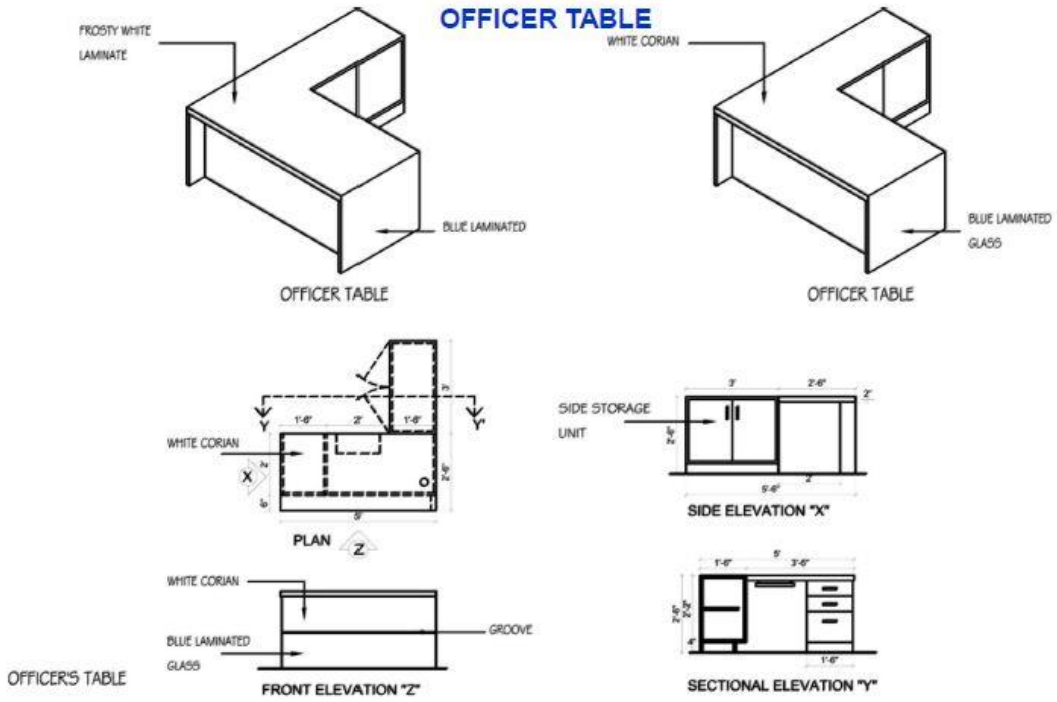

FURNITURE DETAIL

BANKING COUNTER

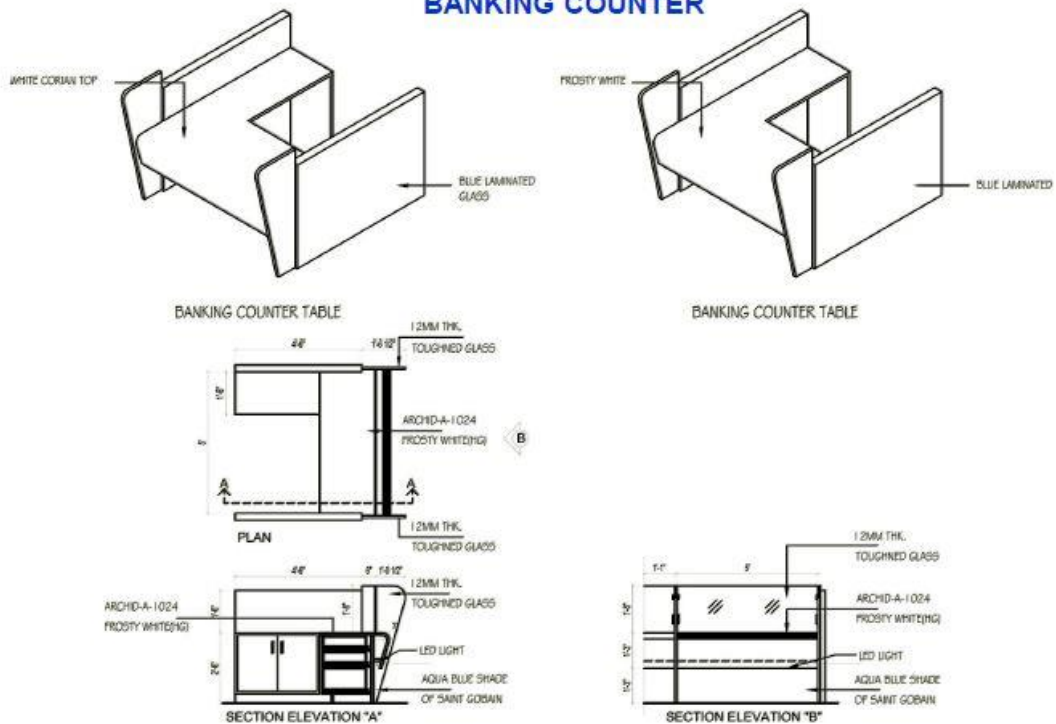

FURNITURE DETAIL

WALL MOUNTED WRITING DESK

